

July 2006

No. OC308

REVISED EDITION-A

TECHNICAL & SERVICE MANUAL

Series PCFY Ceiling Suspended **R410A** / **R407C** / **R22**

<Indoor unit>
[Model name]

PCFY-P40VGM-E

PCFY-P63VGM-E

PCFY-P100VGM-E

PCFY-P125VGM-E

[Service Ref.]

PCFY-P40VGM-E

PCFY-P63VGM-E

PCFY-P100VGM-E

PCFY-P125VGM-E

Revision:

- RoHS PARTS LIST is added.
- Some descriptions have been modified.

- Please void OC308.

Note:

- This manual describes only service data of the indoor units.
- RoHS compliant products have <G> mark on the spec name plate.
- For servicing of RoHS compliant products, refer to the RoHS Parts List.

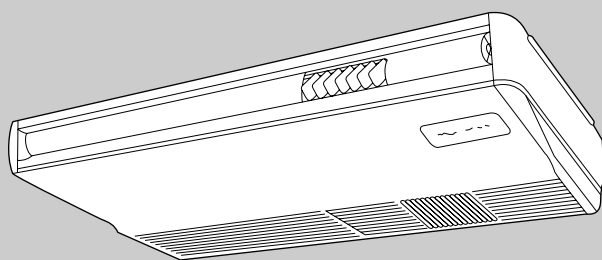

INDOOR UNIT

CONTENTS

1. SAFETY PRECAUTION	2
2. PART NAMES AND FUNCTIONS	6
3. SPECIFICATIONS	8
4. OUTLINES AND DIMENSIONS	11
5. WIRING DIAGRAM	15
6. REFRIGERANT SYSTEM DIAGRAM ..	16
7. TROUBLE SHOOTING	17
8. DISASSEMBLY PROCEDURE	24
9. PARTS LIST	28
10. RoHS PARTS LIST	35
11. OPTIONAL PARTS	42

1

SAFETY PRECAUTION

CAUTIONS RELATED TO NEW REFRIGERANT

Cautions for units utilizing refrigerant R407C

Do not use the existing refrigerant piping.

The old refrigerant and lubricant in the existing piping contains a large amount of chlorine which may cause the lubricant deterioration of the new unit.

Use liquid refrigerant to seal the system.

If gas refrigerant is used to seal the system, the composition of the refrigerant in the cylinder will change and performance may drop.

Use "low residual oil piping"

If there is a large amount of residual oil (hydraulic oil, etc.) inside the piping and joints, deterioration of the lubricant will result.

Do not use a refrigerant other than R407C.

If another refrigerant (R22, etc.) is used, the chlorine in the refrigerant may cause the lubricant deterioration.

Store the piping to be used during installation indoors with keep both ends sealed until just before brazing. (Store elbows and other joints in a plastic bag.)

If dust, dirt, or water enters the refrigerant cycle, deterioration of the oil and compressor trouble may result.

Use a vacuum pump with a reverse flow check valve.

The vacuum pump oil may flow back into the refrigerant cycle and cause the lubricant deterioration.

Use ESTR , ETHER or HAB as the lubricant to coat flares and flange connection parts.

If large amount of mineral oil enter, that can cause deterioration of refrigerant oil etc.

Ventilate the room if refrigerant leaks during operation. If refrigerant comes into contact with a flame, poisonous gases will be released.

[1] Cautions for service

- After recovering the all refrigerant in the unit, proceed to working.
- Do not release refrigerant in the air.
- After completing the repair service, recharge the cycle with the specified amount of liquid refrigerant.

[2] Refrigerant recharging

(1) Refrigerant recharging process

- ①Direct charging from the cylinder.
 - R407C cylinder are available on the market has a syphon pipe.
 - Leave the syphon pipe cylinder standing and recharge it.
(By liquid refrigerant)

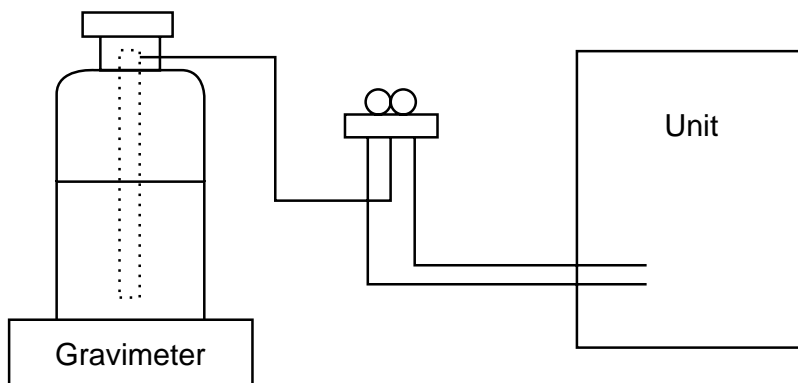

(2) Recharge in refrigerant leakage case

- After recovering the all refrigerant in the unit, proceed to working.
- Do not release the refrigerant in the air.
- After completing the repair service, recharge the cycle with the specified amount of liquid refrigerant.



[3] Service tools

Use the below service tools as exclusive tools for R407C refrigerant.

No.	Tool name	Specifications
①	Gauge manifold	·Only for R407C.
		·Use the existing fitting SPECIFICATIONS. (UNF7/16)
		·Use high-tension side pressure of 3.43MPa-G or over.
②	Charge hose	·Only for R407C.
		·Use pressure performance of 5.10MPa-G or over.
③	Electronic scale	
④	Gas leak detector	·Use the detector for R134a or R407C.
⑤	Adapter for reverse flow check.	·Attach on vacuum pump.
⑥	Refrigerant charge base.	
⑦	Refrigerant cylinder.	·For R407C ·Top of cylinder (Brown)
		·Cylinder with syphon
⑧	Refrigerant recovery equipment.	

Cautions for units utilizing refrigerant R410A

Do not use the existing refrigerant piping.

The old refrigerant and lubricant in the existing piping contains a large amount of chlorine which may cause the lubricant deterioration of the new unit.

Use "low residual oil piping"

If there is a large amount of residual oil (hydraulic oil, etc.) inside the piping and joints, deterioration of the lubricant will result.

Store the piping to be used during installation indoors and keep both ends of the piping sealed until just before brazing. (Leave elbow joints, etc. in their packaging.)

If dirt, dust or moisture enter into refrigerant cycle, that can cause deterioration of refrigerant oil or malfunction of compressor.

Use ester oil, ether oil or alkylbenzene oil (small amount) as the refrigerant oil applied to flares and flange connections.

If large amount of mineral oil enter, that can cause deterioration of refrigerant oil etc.

Charge refrigerant from liquid phase of gas cylinder.

If the refrigerant is charged from gas phase, composition change may occur in refrigerant and the efficiency will be lowered.

Do not use refrigerant other than R410A.

If other refrigerant (R22 etc.) is used, chlorine in refrigerant can cause deterioration of refrigerant oil etc.

Use a vacuum pump with a reverse flow check valve.

Vacuum pump oil may flow back into refrigerant cycle and that can cause deterioration of refrigerant oil etc.

Use the following tools specifically designed for use with R410A refrigerant.

The following tools are necessary to use R410A refrigerant.

Tools for R410A	
Gauge manifold	Flare tool
Charge hose	Size adjustment gauge
Gas leak detector	Vacuum pump adaptor
Torque wrench	Electronic refrigerant charging scale

Keep the tools with care.

If dirt, dust or moisture enter into refrigerant cycle, that can cause deterioration of refrigerant oil or malfunction of compressor.

Do not use a charging cylinder.

If a charging cylinder is used, the composition of refrigerant will change and the efficiency will be lowered.

Ventilate the room if refrigerant leaks during operation. If refrigerant comes into contact with a flame, poisonous gases will be released.

● **Indoor Unit**

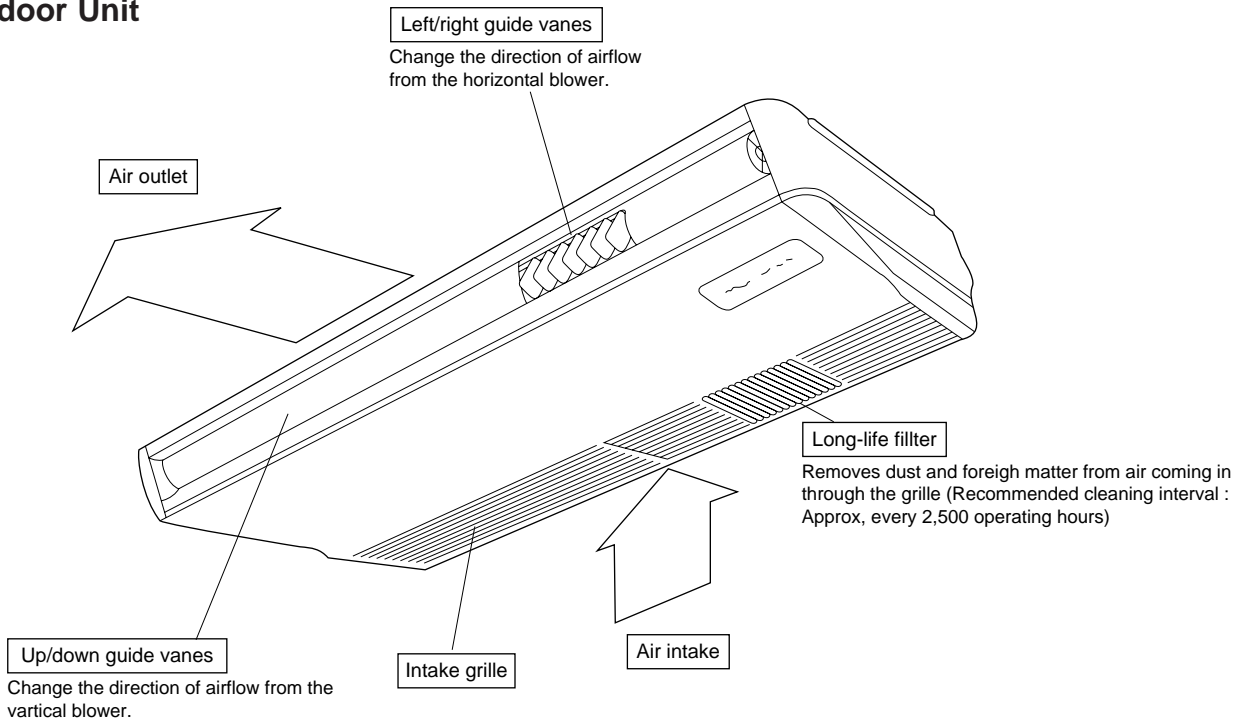

● **Wired remote controller**

On the controls are set, the same operation mode can be repeated by simply pressing the ON/OFF button.

● **Operation buttons**

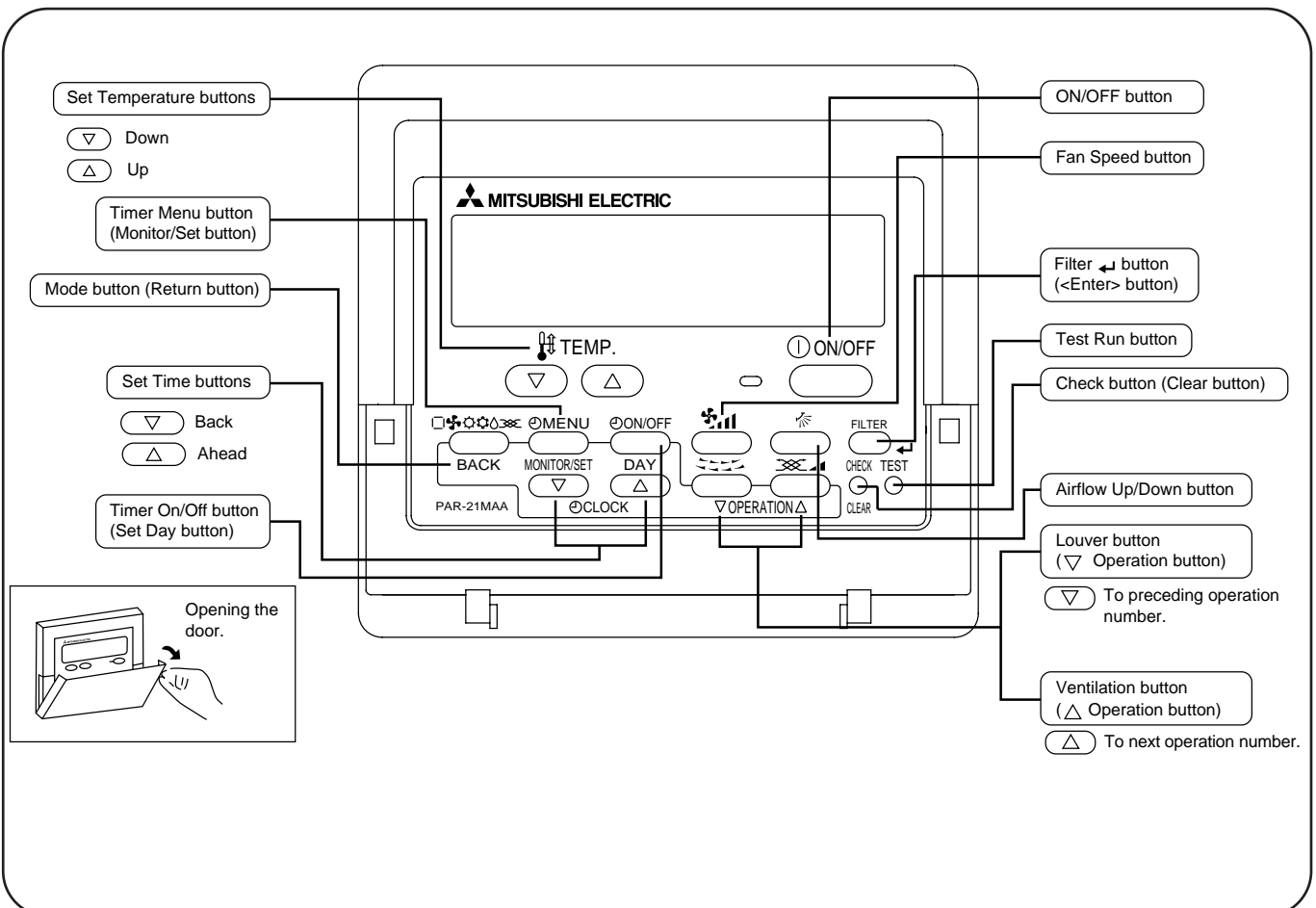

● Display

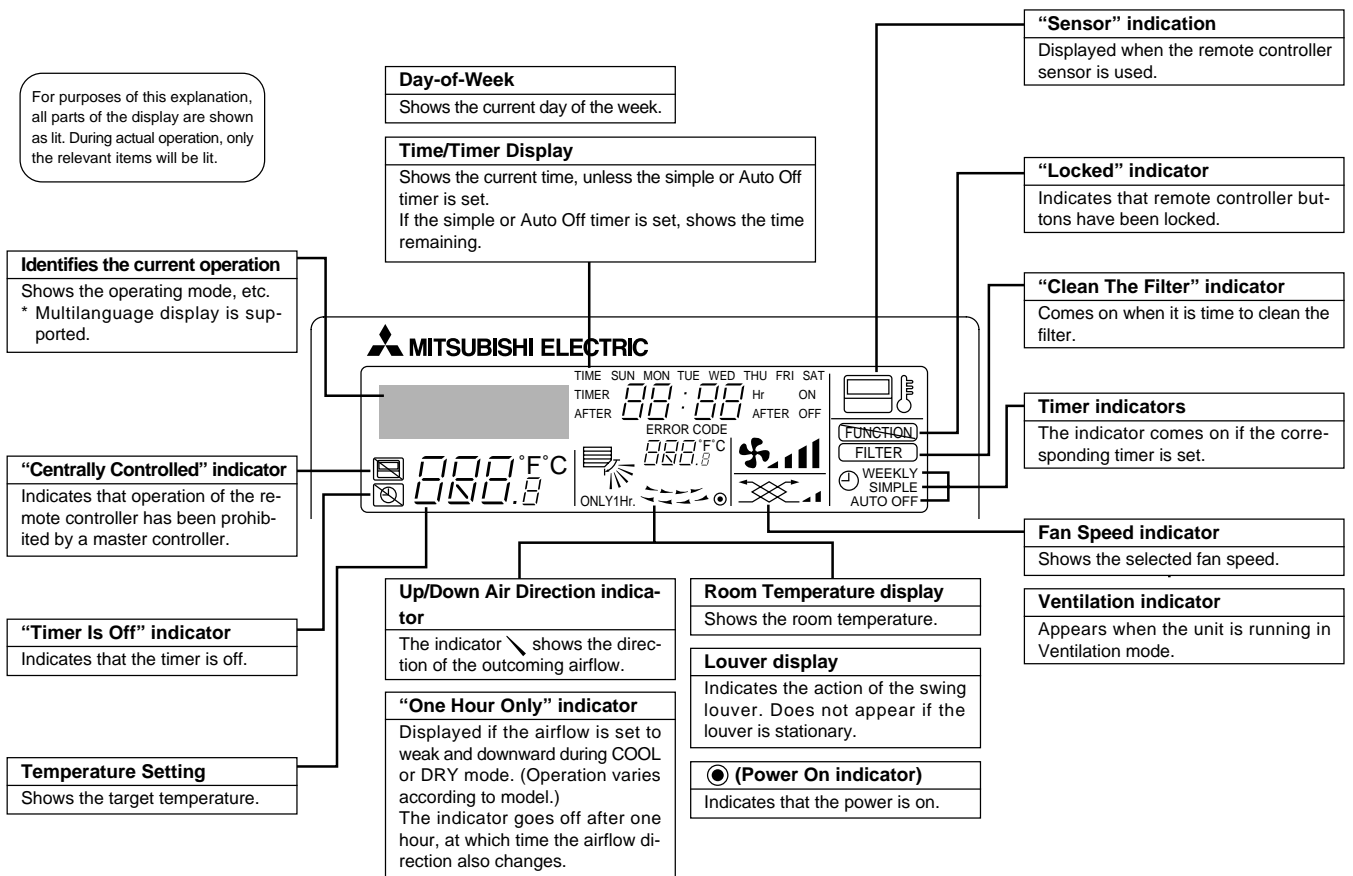

Caution

- Only the Power on indicator lights when the unit is stopped and power supplied to the unit.
- If you press a button for a feature that is not installed at the indoor unit, the remote controller will display the “Not Available” message.
If you are using the remote controller to drive multiple indoor units, this message will appear only if the feature is not present at the parent unit.
- When power is turned ON for the first time, it is normal that “PLEASE WAIT” is displayed on the room temperature indication (For max. 2minutes). Please wait until this “PLEASE WAIT” indication disappear then start the operation.

3-1. SPECIFICATIONS

Item		PCFY-P40VGM-E	PCFY-P63VGM-E	PCFY-P100VGM-E	PCFY-P125VGM-E		
Power	V•Hz	Single phase 220-230-240V 50Hz / 220V 60Hz					
Cooling capacity	kW	4.5	7.1	11.2	14.0		
Heating capacity	kW	5.0	8.0	12.5	16.0		
Electric characteristic	Input	Cooling	kW	0.10	0.13	0.16	0.24
		Heating	kW	0.10	0.13	0.16	0.24
	Current	Cooling	A	0.46	0.60	0.73	1.10
		Heating	A	0.46	0.60	0.73	1.10
Exterior (munsell symbol)	—	Unit : Munsell<0.70Y 8.59/0.97>					
Dimensions	Height	mm	210		270		
	Width	mm	1000	1310	1310	1620	
	Depth	mm	680				
Heat exchanger	—	Cross fin (Aluminum plate fine and copper tube)					
Fan	Fan X No	—	Sirocco fan X 2	Sirocco fan X 3		Sirocco fan X 4	
	Air flow *	m ³ /min	12 -11 -10 -8	18 -16 -14 -12	25 -23 -20 -18	35 -32 -28 -26	
	External static pressure	Pa	0				
	Fan motor output	kW	0.054	0.07	0.09	0.15	
Air filter	—	PP honey comb					
Pipe dimensions	Gas side	φmm(in.)	12.7(1/2")	15.88(5/8")	15.88(5/8") / 19.05(3/4")		
	Liquid side	φmm(in.)	6.35(1/4")	9.52(3/8")	9.52(3/8")		
Unit drain pipe size	φmm	I.D.26 (PVC pipe VP-20 connectable)					
Noise level *	dB	38 -36 -33 -29	39 -37 -34 -32	43 -41 -38 -36	44 -42 -39 -37		
Product weight	kg	27	34	37	43		

Note 1. Rating conditions(JIS B 8615-1)
Cooling : Indoor : D.B. 27°C W.B. 19°C
 outdoor : D.B. 35°C
Heating : Indoor : D.B. 20°C
 outdoor : D.B. 7°C W.B. 6°C

* Air flow and the noise level are indicated as High – Middium1 – Middium2 – Low.

3-2. ELECTRICAL PARTS SPECIFICATIONS

Model Parts name	Symbol	PCFY-P40VGM-E	PCFY-P63VGM-E	PCFY-P100VGM-E	PCFY-P125VGM-E
Room temperature thermistor	TH21	Resistance 0°C /15kΩ, 10°C /9.6kΩ, 20°C /6.3kΩ, 25°C /5.4kΩ, 30°C /4.3kΩ, 40°C /3.0kΩ			
Liquid pipe temperature thermistor	TH22	Resistance 0°C /15kΩ, 10°C /9.6kΩ, 20°C /6.3kΩ, 25°C /5.4kΩ, 30°C /4.3kΩ, 40°C /3.0kΩ			
Gas pipe temperature thermistor	TH23	Resistance 0°C /15kΩ, 10°C /9.6kΩ, 20°C /6.3kΩ, 25°C /5.4kΩ, 30°C /4.3kΩ, 40°C /3.0kΩ			
Fuse (Indoor controller board)	FUSE	250V 6.3A			
Fan motor (with inner-thermostat)	MF	4-Pole Output 54W D09B4P54MS	4-Pole Output 70W D09C4P70MS	4-Pole Output 90W D10B4P90MS	4-Pole Output 150W D10B4P150MS
		Inner-thermostat OFF 130°C ±5°C			
Fan motor capacitor	C1	3μF X 440V	4μF X 440V	4μF X 440V	6μF X 440V
Vane motor	MV	MP35EA DC12V		MP42EA DC12V	
Linear expansion valve	LEV	DC12V Stepping motor drive φ3.2 (0~2000pulse)	DC12V Stepping motor drive φ3.2 (0~2000pulse)		
Power supply terminal block	TB2	(L, N, ⊕) 330V 30A			
Transmission terminal block	TB5	(M1, M2, S) 250V 20A			
MA remote controller terminal block	TB15	(1, 2) 250V 10A			

3-3. NOISE CRITERION CURVES

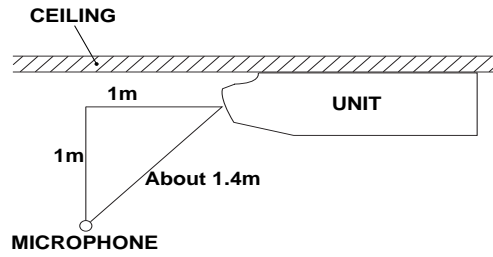

PCFY-P40VGM-E

NOTCH	SPL(dB)	LINE
Hi	35	○—○
Mi1	33	△—△
Mi2	30	▲—▲
Lo	27	●—●

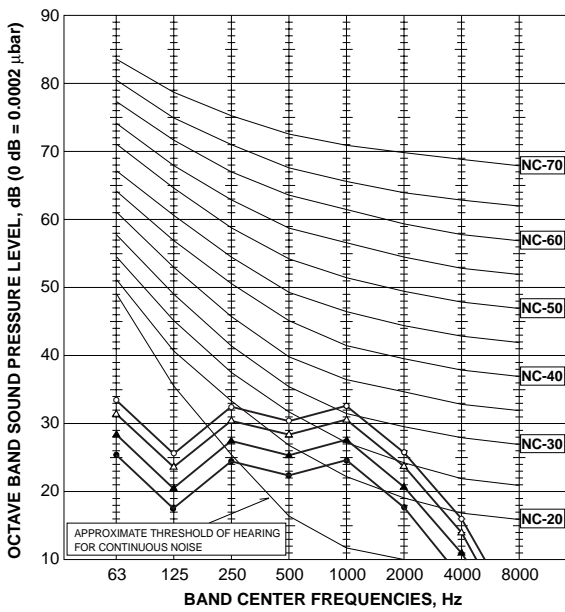

PCFY-P63VGM-E

NOTCH	SPL(dB)	LINE
Hi	37	○—○
Mi1	36	△—△
Mi2	34	▲—▲
Lo	32	●—●

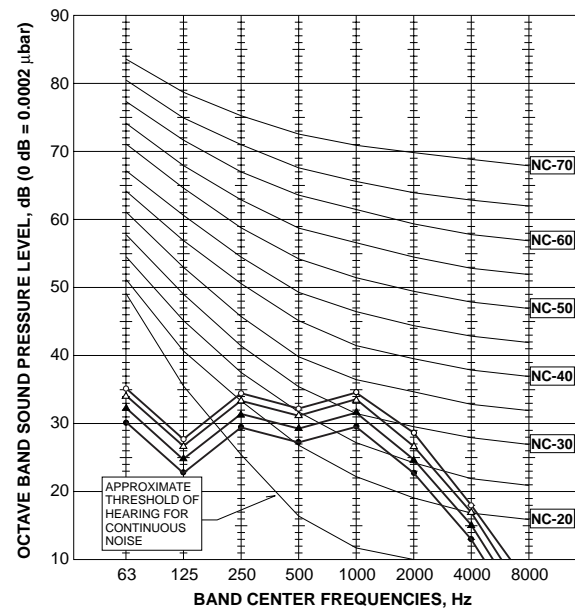

PCFY-P100VGM-E

NOTCH	SPL(dB)	LINE
Hi	39	○—○
Mi1	37	△—△
Mi2	35	▲—▲
Lo	33	●—●

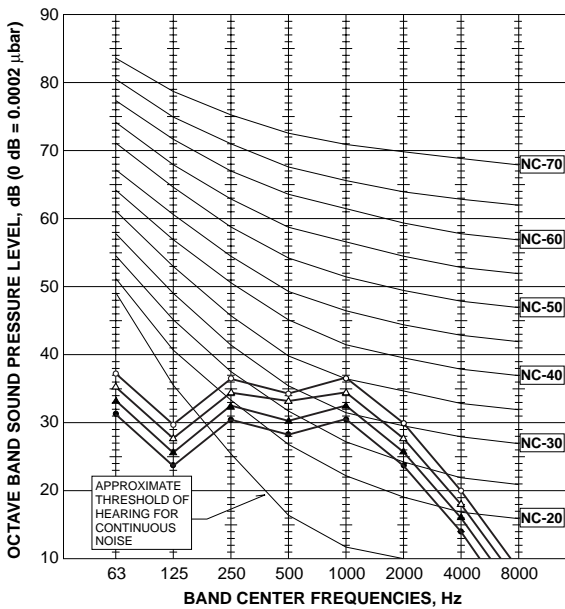

PCFY-P125VGM-E

NOTCH	SPL(dB)	LINE
Hi	39	○—○
Mi1	37	△—△
Mi2	35	▲—▲
Lo	33	●—●

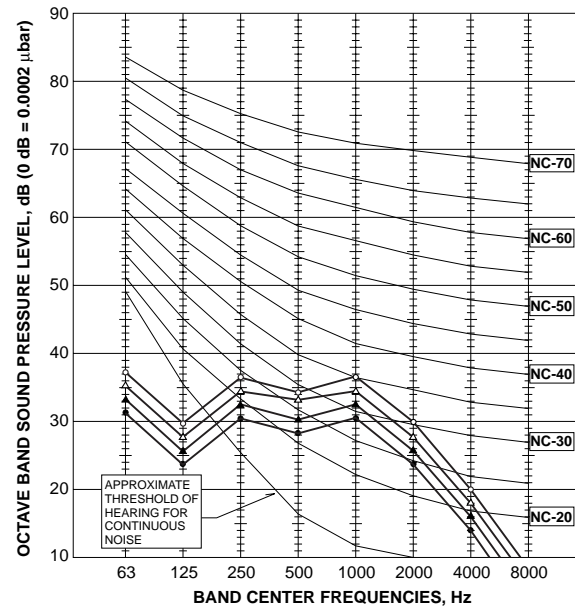

INDOOR UNIT
PCFY-P40VGM-E

Unit : mm

- ① Drainage pipe connection (26mm I.D.)
- ② Drainage pipe connection (for the left arrangement)
- ③ Knock out hole for left drain-piping arrangement
- ④ Refrigerant-pipe connection (gas pipe side/flared connection)
- ⑤ Refrigerant-pipe connection (liquid pipe side/flared connection)
- ⑥ Knock out hole for upper drain pipe arrangement
- ⑦ Knock out hole for left drain pipe arrangement
- ⑧ Knock out hole for wiring arrangement

NOTES:

- 1. Use M10 or W3/8 screws for anchor bolt.
- 2. Please be sure when installing the drain-up machine (option parts).
refrigerant pipe will be only upper drain pipe arrangement.

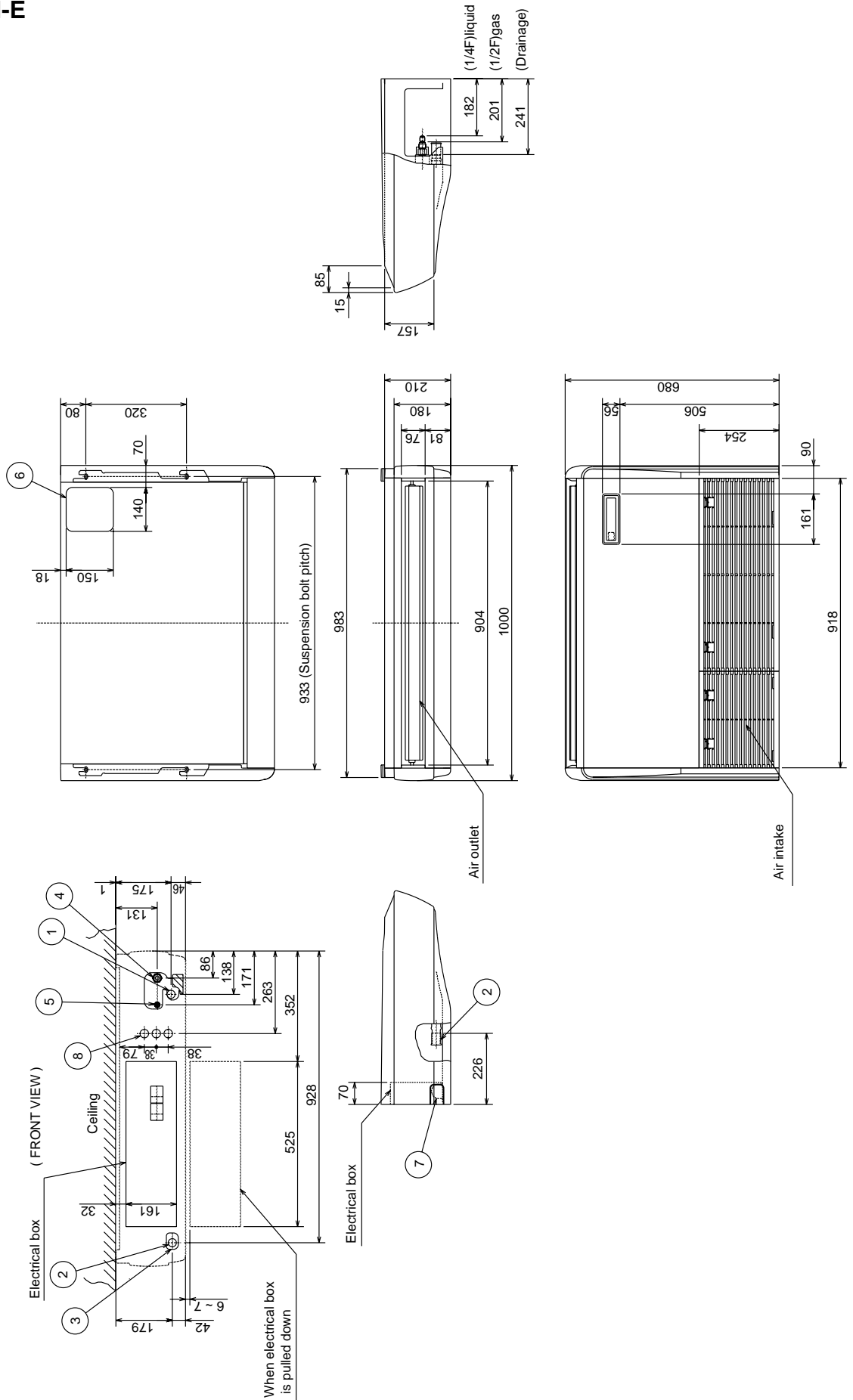

PCFY-P63VGM-E

Unit : mm

- ① Drainage pipe connection (26mm I.D.)
- ② Drainage pipe connection (for the left arrangement)
- ③ Knock out hole for left drain-piping arrangement
- ④ Refrigerant-pipe connection (gas pipe side/flared connection)
- ⑤ Refrigerant-pipe connection (liquid pipe side/flared connection)
- ⑥ Knock out hole for upper drain pipe arrangement
- ⑦ Knock out hole for left drain pipe arrangement
- ⑧ Knock out hole for wiring arrangement

NOTES:

- 1. Use M10 or W3/8 screws for anchor bolt.
- 2. Please be sure when installing the drain-up machine (option parts).
refrigerant pipe will be only upper drain pipe arrangement.

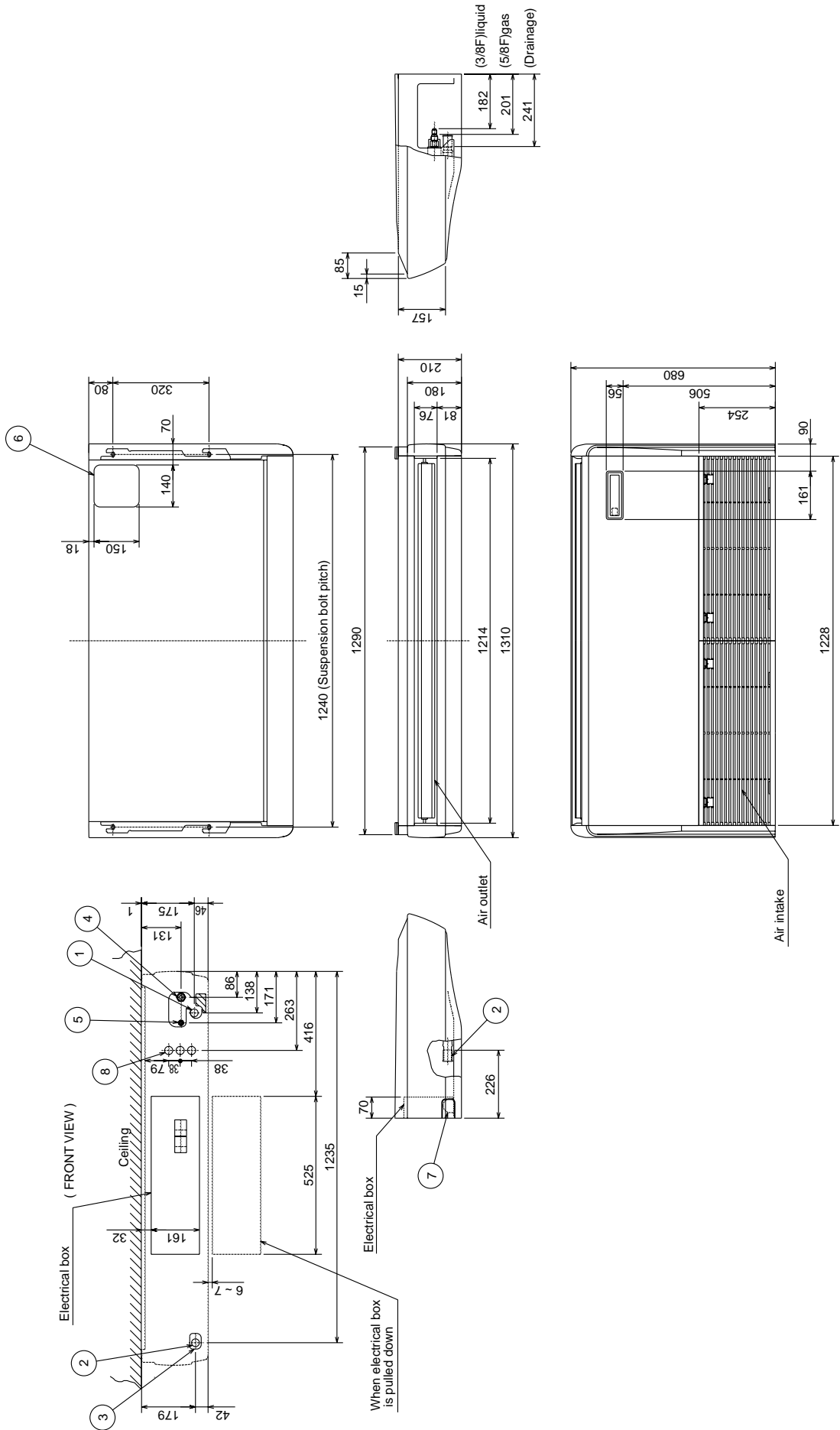

PCFY-P100VGM-E

Unit : mm

- ① Drainage pipe connection (26mm I.D.)
 - ② Drainage pipe connection (for the left arrangement)
 - ③ Knock out hole for left drain-piping arrangement
 - ④ Refrigerant-pipe connection (gas pipe side/flared connection)
 - ⑤ Refrigerant-pipe connection (liquid pipe side/flared connection)
 - ⑥ Knock out hole for upper drain pipe arrangement
 - ⑦ Knock out hole for left drain pipe arrangement
 - ⑧ Knock out hole for wiring arrangement
- NOTES:
 1. Use M10 or W3/8 screws for anchor bolt.
 2. Please be sure when installing the drain-up machine (option parts).
 refrigerant pipe will be only upper drain pipe arrangement.

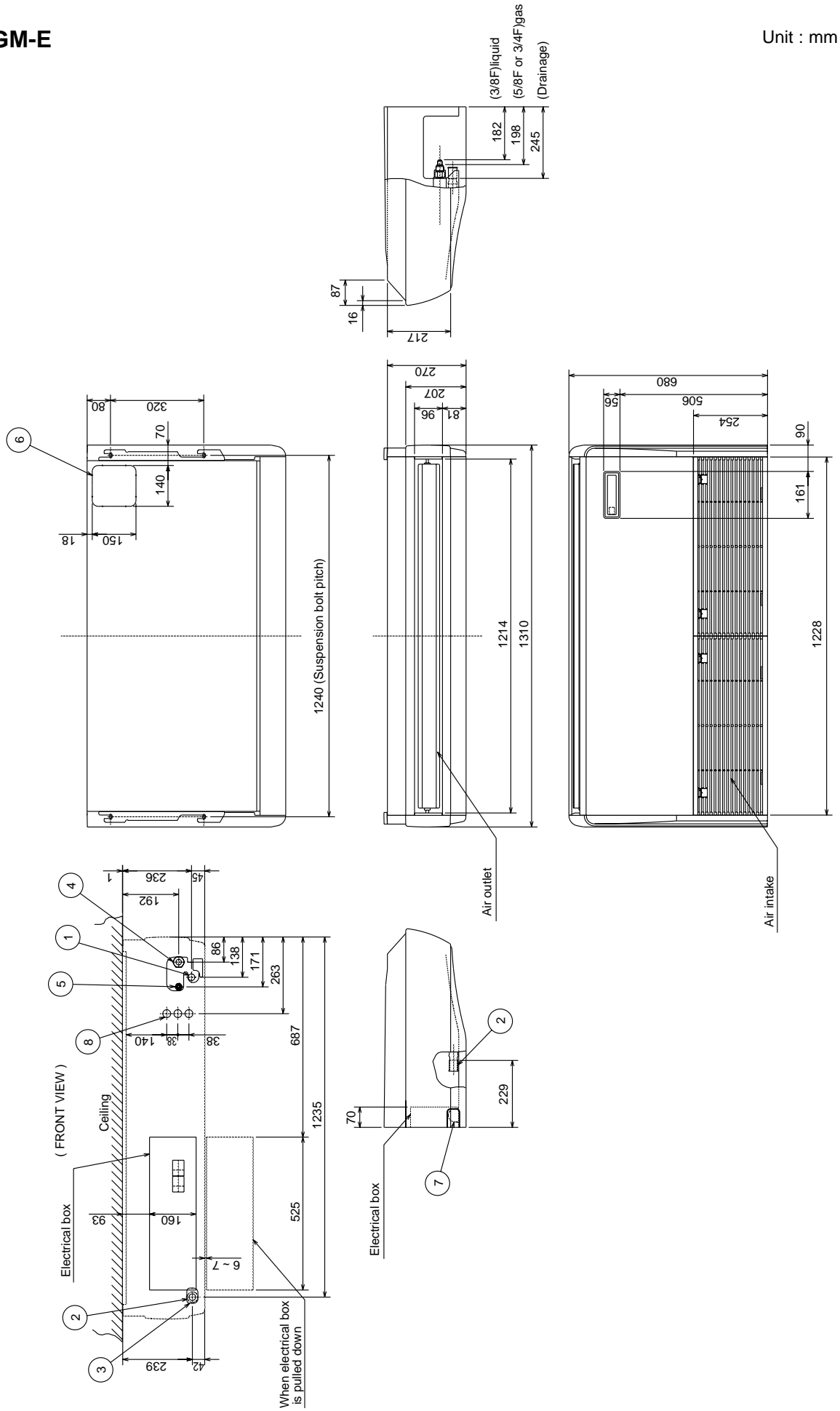

PCFY-P125VGM-E

Unit : mm

- ① Drainage pipe connection (26mm I.D.)
- ② Drainage pipe connection (for the left arrangement)
- ③ Knock out hole for left drain-piping arrangement
- ④ Refrigerant-pipe connection (gas pipe side/flared connection)
- ⑤ Refrigerant-pipe connection (liquid pipe side/flared connection)
- ⑥ Knock out hole for upper drain pipe arrangement
- ⑦ Knock out hole for left drain pipe arrangement
- ⑧ Knock out hole for wiring arrangement

NOTES:
 1. Use M10 or W3/8 screws for anchor bolt.
 2. Please be sure when installing the drain-up machine (option parts).
 refrigerant pipe will be only upper drain pipe arrangement.

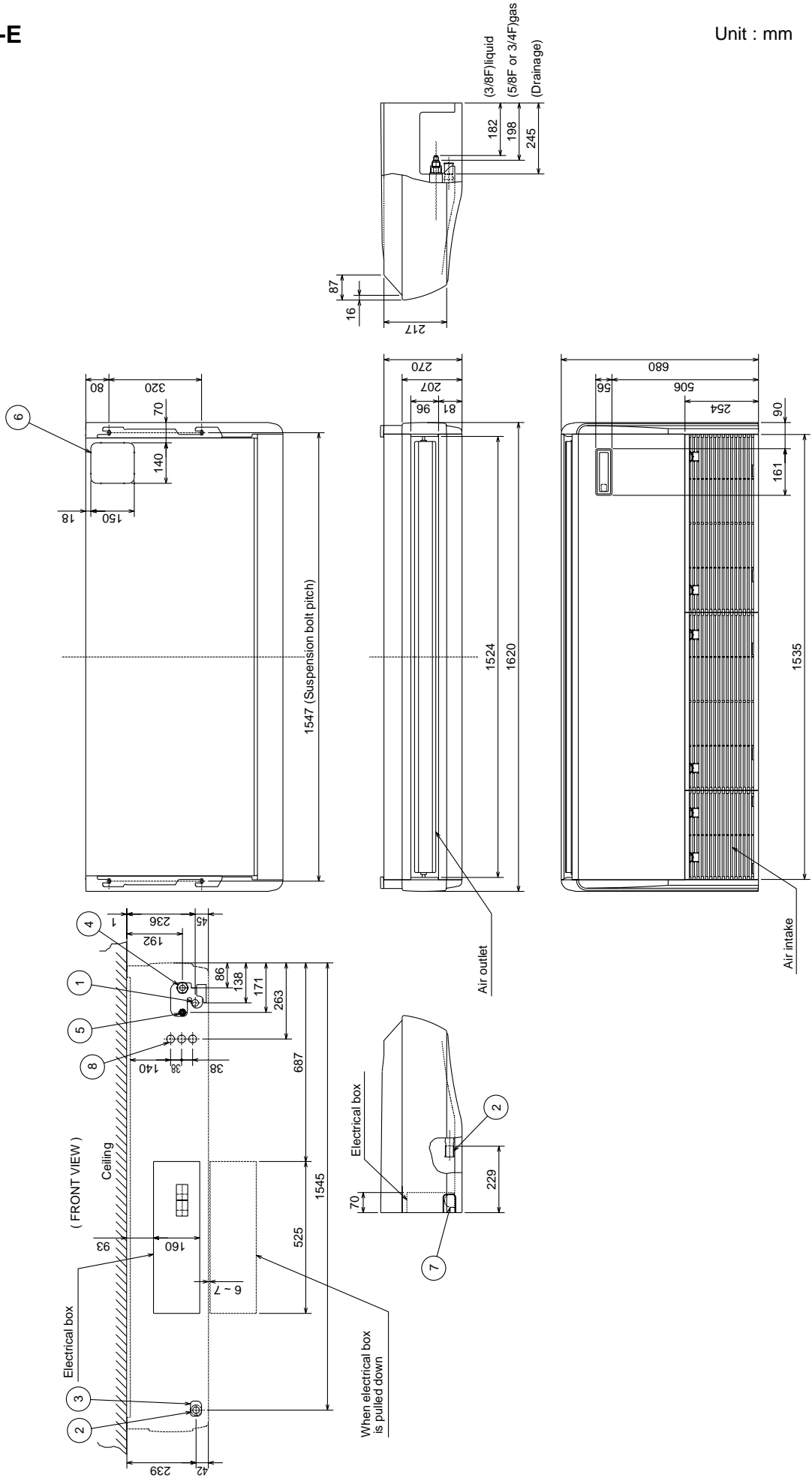

5

WIRING DIAGRAM

PCFY-P40VGM-E PCFY-P63VGM-E PCFY-P100VGM-E PCFY-P125VGM-E

Legend

Symbol	Name	Symbol	Name	Symbol	Name	
I.B	Indoor controller board	C1	Capacitor(fan motor)	A.B	Circuit board	
CN32	Connector	LEV	Linear expansion valve	SW1	Switch	
CN51	Centrally control	MF	Fan motor(with inner thermo)	SW5	Mode selection	
CN52	Remote indication	MV	Vane motor	SW11	Voltage selection	
CNP	Drain-up machine	TH21	Thermistor	SW12	Address setting 1st digit	
F.C	Fan phase control	TH22		Room temperature,detection (0°C/15kΩ,25°C/5.4kΩ)	SW14	Address setting 2nd digit
FUSE	FUSE (6.3A)	TH23	Pipe temperature,detection/liquid (0°C/15kΩ,25°C/5.4kΩ)	SWA	Ceiling heigh selector	
SW2	Switch	TB2	Pipe temperature,detection/Gas (0°C/15kΩ,25°C/5.4kΩ)	SWC	Option selector	
SW3	Capacity code		Terminal block	Power supply		
SW4	Mode selection			Transmission		
X1	Aux.Relay	TB5	MA-remote controller			
X4	Fan motor	TB15				
ZNR	Varistor					
P.B	INDOOR POWER BOARD	DP	Drain-up machine (OPTION)			
		DS	Drain sensor (OPTION)			

LED on indoor board for service

Mark	Meaning	Function
LED1	Main power supply	Main power supply(Indoor unit:220-240V) power on → lamp is lit
LED2	Power supply for MA-Remote controller	Power supply for MA-Remote controller on → lamp is lit

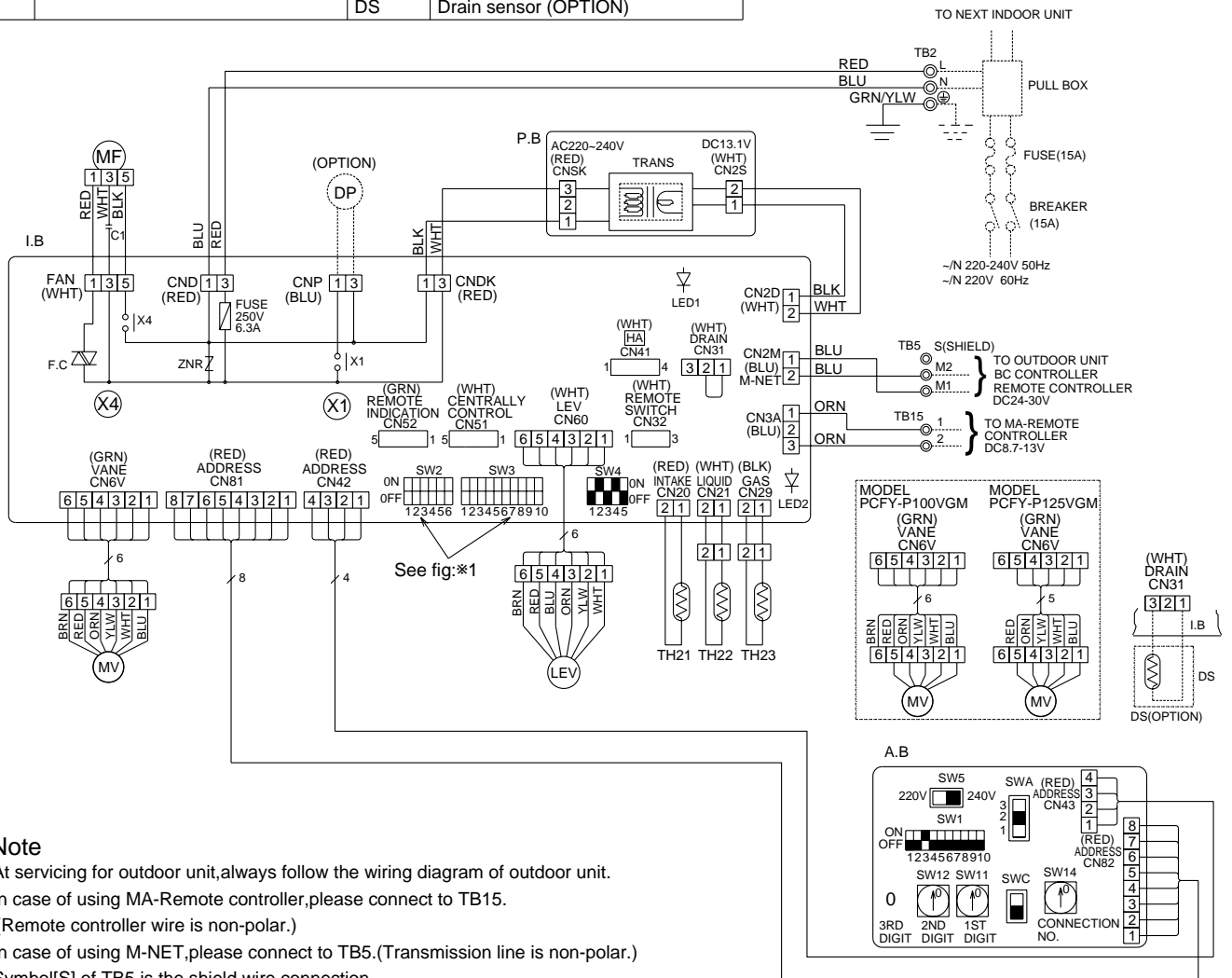

Note

- At servicing for outdoor unit, always follow the wiring diagram of outdoor unit.
- In case of using MA-Remote controller, please connect to TB15.
(Remote controller wire is non-polar.)
- In case of using M-NET, please connect to TB5. (Transmission line is non-polar.)
- Symbol[S] of TB5 is the shield wire connection.
- Symbols used in wiring diagram above are, ⊙: terminal block, □: connector.
- The setting of the SW2 dip switches differs in the capacity.
For the detail, refer to the fig: * 1.
- Please set the switch SW5 according to the power supply voltage.
Set SW5 to 240V side when the power supply is 230 and 240 volts.
When the power supply is 220 volts, set SW5 to 220V side.
- Fasten terminal of the terminal board "TB5" equips lock system.
To remove the fasten terminal, pull it while pressing the protruding portion (locking level) of the terminal. Connection of the fasten terminal, protruding portion should face upward.

[*1]

Models	SW2	SW3
PCFY-P40VGM	ON OFF	ON OFF
PCFY-P63VGM	ON OFF	ON OFF
PCFY-P100VGM	ON OFF	ON OFF
PCFY-P125VGM	ON OFF	ON OFF

6

REFRIGERANT SYSTEM DIAGRAM

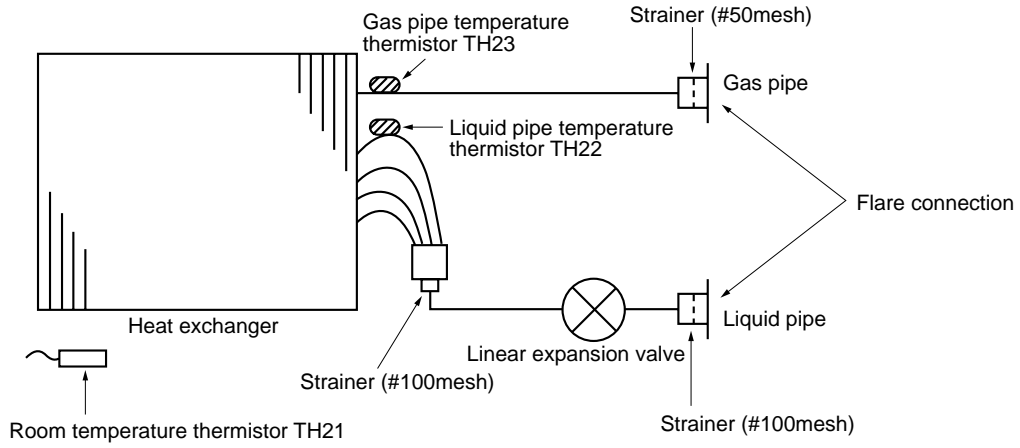

PCFY-P40VGM-E
 PCFY-P63VGM-E
 PCFY-P100VGM-E
 PCFY-P125VGM-E



Item \ Capacity	PCFY-P40VGM-E	PCFY-P63VGM-E	PCFY-P100VGM-E PCFY-P125VGM-E
Gas pipe	φ12.7(1/2")	φ15.88(5/8")	φ15.88(5/8") or φ19.05(3/4")
Liquid pipe	φ6.35(1/4")	φ9.52(3/8")	φ9.52(3/8")

7-1. How to check the parts

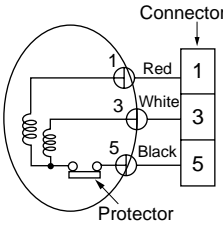
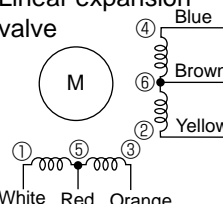
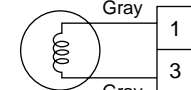
PCFY-P40VGM-E PCFY-P63VGM-E PCFY-P100VGM-E PCFY-P125VGM-E

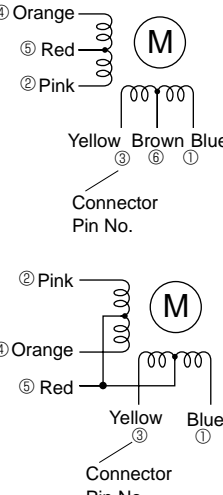
Parts name	Check points																									
Room temperature thermistor (TH21) Liquid pipe temperature thermistor (TH22) Gas pipe temperature thermistor (TH23)	Disconnect the connector then measure the resistance using a tester. (Surrounding temperature 10°C ~30°C) <table border="1" style="margin-left: 20px;"> <thead> <tr> <th>Normal</th> <th>Abnormal</th> </tr> </thead> <tbody> <tr> <td>4.3kΩ~9.6kΩ</td> <td>Open or short</td> </tr> </tbody> </table> Refer to the next page for the details.	Normal	Abnormal	4.3kΩ~9.6kΩ	Open or short																					
Normal	Abnormal																									
4.3kΩ~9.6kΩ	Open or short																									
Fan motor 	Measure the resistance between the terminals using a tester. <table border="1" style="margin-left: 20px;"> <thead> <tr> <th rowspan="3">Motor terminal or Connector</th> <th colspan="4">Normal</th> <th rowspan="3">Abnormal</th> </tr> <tr> <th colspan="4">PCFY-</th> </tr> <tr> <th>P40VGM-E</th> <th>P63VGM-E</th> <th>P100VGM-E</th> <th>P125VGM-E</th> </tr> </thead> <tbody> <tr> <td>Red-Black</td> <td>70.6Ω</td> <td>45.0Ω</td> <td>43.7Ω</td> <td>20.4Ω</td> <td rowspan="2">Open or short</td> </tr> <tr> <td>White-Black</td> <td>69.6Ω</td> <td>44.8Ω</td> <td>53.3Ω</td> <td>20.7Ω</td> </tr> </tbody> </table>	Motor terminal or Connector	Normal				Abnormal	PCFY-				P40VGM-E	P63VGM-E	P100VGM-E	P125VGM-E	Red-Black	70.6Ω	45.0Ω	43.7Ω	20.4Ω	Open or short	White-Black	69.6Ω	44.8Ω	53.3Ω	20.7Ω
Motor terminal or Connector	Normal				Abnormal																					
	PCFY-																									
	P40VGM-E	P63VGM-E	P100VGM-E	P125VGM-E																						
Red-Black	70.6Ω	45.0Ω	43.7Ω	20.4Ω	Open or short																					
White-Black	69.6Ω	44.8Ω	53.3Ω	20.7Ω																						
Linear expansion valve 	Disconnect the connector then measure the resistance valve using a tester. <table border="1" style="margin-left: 20px;"> <thead> <tr> <th colspan="4">Normal</th> <th rowspan="3">Abnormal</th> </tr> <tr> <th>(1)-(5)</th> <th>(2)-(6)</th> <th>(3)-(5)</th> <th>(4)-(6)</th> </tr> <tr> <th>White-Red</th> <th>Yellow-Brown</th> <th>Orange-Red</th> <th>Blue-Brown</th> </tr> </thead> <tbody> <tr> <td colspan="4" style="text-align: center;">150kΩ ±10%</td> <td rowspan="2">Open or short</td> </tr> <tr> <td colspan="4"></td> </tr> </tbody> </table> Refer to the next page for the details.	Normal				Abnormal	(1)-(5)	(2)-(6)	(3)-(5)	(4)-(6)	White-Red	Yellow-Brown	Orange-Red	Blue-Brown	150kΩ ±10%				Open or short							
Normal				Abnormal																						
(1)-(5)	(2)-(6)	(3)-(5)	(4)-(6)																							
White-Red	Yellow-Brown	Orange-Red	Blue-Brown																							
150kΩ ±10%				Open or short																						
Drain-up machine (Optional) 	Measure the resistance between the terminals using a tester. (Surrounding temperature 20°C ~30°C) <table border="1" style="margin-left: 20px;"> <thead> <tr> <th>Normal</th> <th>Abnormal</th> </tr> </thead> <tbody> <tr> <td>92Ω</td> <td>Open or short</td> </tr> </tbody> </table>	Normal	Abnormal	92Ω	Open or short																					
Normal	Abnormal																									
92Ω	Open or short																									
Drain sensor (Optional) 	Measure the resistance after 3 minutes have passed since the power supply was intercepted. (Surrounding temperature 0°C ~60°C) <table border="1" style="margin-left: 20px;"> <thead> <tr> <th>Normal</th> <th>Abnormal</th> </tr> </thead> <tbody> <tr> <td>0.6kΩ~6.0kΩ</td> <td>Open or short</td> </tr> </tbody> </table>	Normal	Abnormal	0.6kΩ~6.0kΩ	Open or short																					
Normal	Abnormal																									
0.6kΩ~6.0kΩ	Open or short																									
Vane motor 	Measure the resistance between the terminals using a tester. (Surrounding temperature 20°C ~30°C) <table border="1" style="margin-left: 20px;"> <thead> <tr> <th rowspan="2">Connector</th> <th colspan="2">Normal</th> <th rowspan="2">Abnormal</th> </tr> <tr> <th>PCFY-P40VGM-E</th> <th>PCFY-P63VGM-E</th> </tr> </thead> <tbody> <tr> <td>Brown — Yellow</td> <td rowspan="4" style="text-align: center;">186~214Ω</td> <td rowspan="4" style="text-align: center;">140~160Ω</td> <td rowspan="4">Open or short</td> </tr> <tr> <td>Brown — Blue</td> </tr> <tr> <td>Red — Orange</td> </tr> <tr> <td>Red — Pink</td> </tr> </tbody> </table> <table border="1" style="margin-left: 20px;"> <thead> <tr> <th rowspan="2">Connector</th> <th colspan="2">Normal</th> <th rowspan="2">Abnormal</th> </tr> <tr> <th colspan="2">PCFY-P100VGM-E, PCFY-P125VGM-E</th> </tr> </thead> <tbody> <tr> <td>Red — Blue</td> <td rowspan="4" style="text-align: center;">140~160Ω</td> <td rowspan="4">Open or short</td> </tr> <tr> <td>Red — Yellow</td> </tr> <tr> <td>Red — Pink</td> </tr> <tr> <td>Red — Orange</td> </tr> </tbody> </table>	Connector	Normal		Abnormal	PCFY-P40VGM-E	PCFY-P63VGM-E	Brown — Yellow	186~214Ω	140~160Ω	Open or short	Brown — Blue	Red — Orange	Red — Pink	Connector	Normal		Abnormal	PCFY-P100VGM-E, PCFY-P125VGM-E		Red — Blue	140~160Ω	Open or short	Red — Yellow	Red — Pink	Red — Orange
Connector	Normal		Abnormal																							
	PCFY-P40VGM-E	PCFY-P63VGM-E																								
Brown — Yellow	186~214Ω	140~160Ω	Open or short																							
Brown — Blue																										
Red — Orange																										
Red — Pink																										
Connector	Normal		Abnormal																							
	PCFY-P100VGM-E, PCFY-P125VGM-E																									
Red — Blue	140~160Ω	Open or short																								
Red — Yellow																										
Red — Pink																										
Red — Orange																										

<Thermistor Characteristic graph>

Thermistor at lower temperature

Room temperature thermistor (TH21)
 Liquid pipe temperature thermistor (TH22)
 Gas pipe temperature thermistor (TH23)

Thermistor $R_0 = 15k\Omega \pm 3\%$

Fixed number of $B = 3480K \pm 2\%$

$$R_t = 15 \exp \left\{ 3480 \left(\frac{1}{273+t} - \frac{1}{273} \right) \right\}$$

0°C	15kΩ
10°C	9.6kΩ
20°C	6.3kΩ
25°C	5.4kΩ
30°C	4.3kΩ
40°C	3.0kΩ

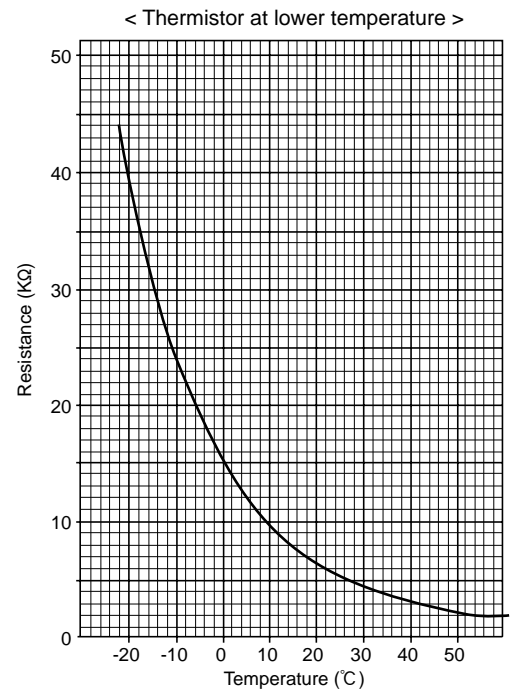

Linear expansion valve

① Operation summary of the linear expansion valve.

- Linear expansion valve open/close through stepping motor after receiving the pulse signal from the indoor controller board.
- Valve opening can be changed in proportion to the number of pulse signal.

<Connection between the indoor controller board and the linear expansion valve>

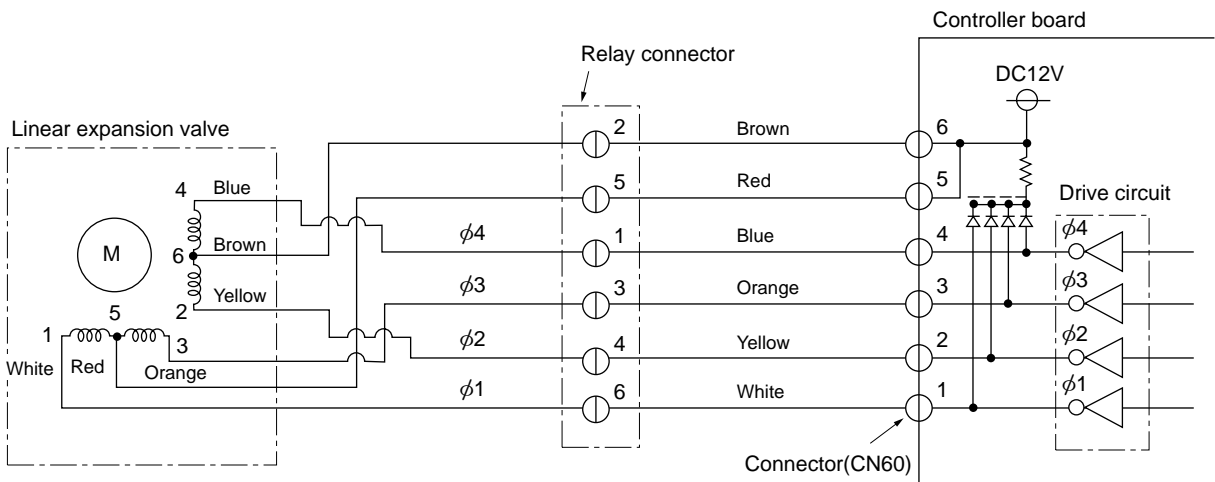

Note : Since the number of the connector at the controller board side and the relay connector are different, follow the color of the lead wire.

<Output pulse signal and the valve operation>

Output (Phase) number	Output			
	1	2	3	4
φ1	ON	OFF	OFF	ON
φ2	ON	ON	OFF	OFF
φ3	OFF	ON	ON	OFF
φ4	OFF	OFF	ON	ON

Closing a valve : 1 → 2 → 3 → 4 → 1
 Opening a valve : 4 → 3 → 2 → 1 → 4

The output pulse shift as above order.

- * 1. When linear expansion valve operation stops, all output phase become OFF.
- 2. At phase interruption or when phase does not shift in order, motor does not rotate smoothly and motor will lock and vibrate.

② Linear expansion valve operation

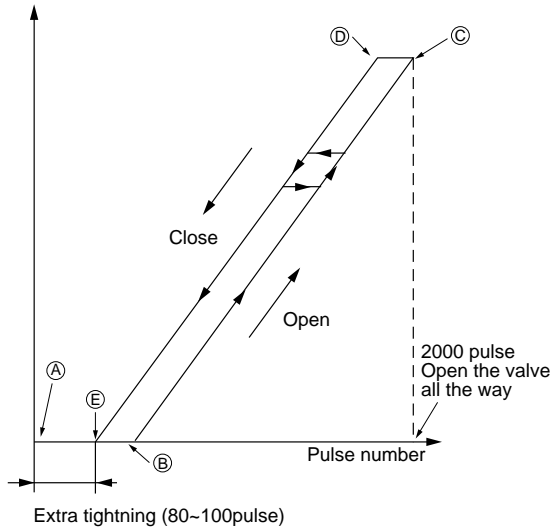

- * When the switch is turned on, 2200 pulse closing valve signal will be send till it goes to A point in order to define the valve position.

When the valve move smoothly, there is no noise or vibration occur from the linear expansion valve : however, when the pulse number moves from E to A or when the valve is locked, more noise can be hear than normal situation.





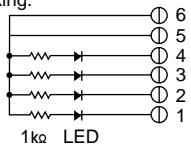
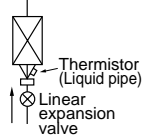





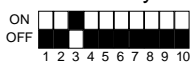



- * Noise can be detected by placing the ear against the screw driver handle while putting the screw driver to the linear expansion valve.

③ Trouble shooting



Symptom	Check points	Countermeasures
Operation circuit failure of the micro processor.	Disconnect the connector on the controller board, then connect LED for checking.  Pulse signal will be sent out for 10 seconds as soon as the main switch is turn on. If there is LED with lights on or lights off, it means the operation circuit is abnormal.	Exchange the indoor controller board at drive circuit failure.
Linear expansion valve mechanism is locked.	Motor will idle and make ticking noise when motor is operated while the linear expansion valve is locked. This ticking sound is the sign of the abnormality.	Exchange the linear expansion vale.
Short or breakage of the motor coil of the linear expansion valve.	Measure the resistance between the each coil (red-white, red-orange, brown-yellow, brown-blue) using a tester. It is normal if the resistance is in the range of 150Ω±10%	Exchange the linear expansion valve.
Valve doesn't close completely (thermistor leaking).	To check the linear expansion valve, operate the indoor unit in fan mode and at the same time operate other indoor units in cooling mode, then check the pipe temperature <liquid pipe temperature> of the indoor unit by the outdoor multi controller board operation monitor. During fan operation, linear expansion valve is closed completely and if there are some leaking, detecting temperature of the thermistor will go lower. If the detected temperature is much lower than the temperature indicated in the remote controller, it means the valve is not closed all the way. It is not necessary to exchange the linear expansion valve, if the leakage is small and not making any trouble. 	If large amount of thermistor is leaked, exchange the linear expansion valve.
Wrong connection of the connector or contact failure.	Check the color of lead wire and missing terminal of the connector.	Disconnect the connector at the controller board, then check the continuity.

7-2. FUNCTION OF DIP SWITCH

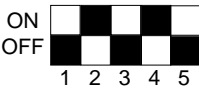
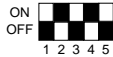
PCFY-P40VGM-E PCFY-P63VGM-E PCFY-P100VGM-E PCFY-P125VGM-E

Switch	Pole	Function	Operation by switch		Remarks																		
			ON	OFF																			
SW1 Mode Selection	1	Room temperature Thermistor position	Built-in remote controller	Indoor unit	<div style="border: 1px solid black; padding: 5px; margin-bottom: 5px;">Address board</div> <At delivery>  NOTE: ※1 At Heating mode, fan operating. ※2 At Heater mode, operating heat thermostat ON. ※3 SW1-7=OFF, SW1-8=ON →Setting air flow. SW1-7=ON, SW1-8=ON →Indoor fan stop.																		
	2	Filter clogging detection	Provided	Not provided																			
	3	Filter cleaning sign	2500hr	100hr																			
	4	Air intake	Effective	Not effective																			
	5	Remote indication switching	Thermostat ON signal indication	Fan output indication																			
	6	Humidifier control	Always operated while the heating mode ※1	Operated depends on the condition ※2																			
	7	Air flow set in case of	Fix to LOW ※3	Fix to EXTRA IOW ※3																			
	8	heat thermostat OFF	Depends on setting remote controller ※3	Depends on SW1-7																			
	9	Auto reset function	Effective	Not effective																			
	10	Power resource ON/OFF	Effective	Not effective																			
SW2 Capacity code setting	1~6	<table border="1" style="width: 100%; text-align: center;"> <thead> <tr> <th>Capacity</th> <th>SW2</th> <th>Capacity</th> <th>SW2</th> <th>Capacity</th> <th>SW2</th> </tr> </thead> <tbody> <tr> <td>PCFY-P40VGM-E</td> <td></td> <td>PCFY-P63VGM-E</td> <td></td> <td>PCFY-P100VGM-E</td> <td></td> </tr> <tr> <td>PCFY-P125VGM-E</td> <td></td> <td></td> <td></td> <td></td> <td></td> </tr> </tbody> </table>			Capacity	SW2	Capacity	SW2	Capacity	SW2	PCFY-P40VGM-E		PCFY-P63VGM-E		PCFY-P100VGM-E		PCFY-P125VGM-E						<div style="border: 1px solid black; padding: 5px; margin-bottom: 5px;">Indoor controller board</div> Set while the unit is off. <At delivery> Set for each capacity.
		Capacity	SW2	Capacity	SW2	Capacity	SW2																
PCFY-P40VGM-E		PCFY-P63VGM-E		PCFY-P100VGM-E																			
PCFY-P125VGM-E																							
SW3 Function Selection	1	Heat pump/Cool only	Cooling only	Heat pump	<div style="border: 1px solid black; padding: 5px; margin-bottom: 5px;">Indoor controller board</div> Set while the unit is off. <At delivery>  NOTE: ※4 At cooling mode, each angle can be used only 1 hour. ※5 SW3-9 setting P40 = ON P63,P100,P125 = OFF																		
	2	Louver	Available	Not available																			
	3	Vane	Available	Not available																			
	4	Vane swing function	Available	Not available																			
	5	Vane horizontal angle	Second setting	First setting																			
	6	Vane cooling limit angle setting ※4	Horizontal angle	Down B,C																			
	7	Indoor linear expansion valve opening	Effective	Not effective																			
	8	Heater 4degrees up	Not effective	Effective																			
	9	Target Superheat setting ※5	9degrees	6degrees																			
	10	Target Subcool setting	15degrees	10degrees																			
SW4 Unit Selection	1~4				<div style="border: 1px solid black; padding: 5px; margin-bottom: 5px;">Indoor controller board</div> Set while the unit is off. <At delivery> 																		

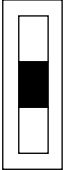
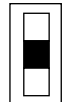
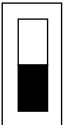
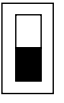
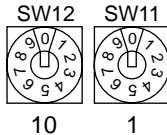
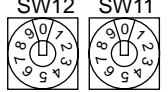

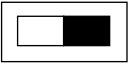
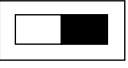
Switch		Operation by switch	Remarks
SWA Set the ceiling height	1~3	<p>※ Ceiling height can be changed depends on SW A setting.</p> <p>(High) 3 (Standard) 2 (Low) 1</p> 	<p>Address board</p> <p><At delivery></p> 
SWC Option	2	<p>Option (Standard)</p>  <p>When the optional high performance filter elements (filter casement) is attached to the unit, be sure to set switch to the option side in order to prevent the airflow reducing.</p>	<p>Address board</p> <p><At delivery></p> <p>Option</p> 
SW11 1st digit address setting SW12 2nd digit address setting	Rotary switch	<p>Address setting should be done when M-NET remote controller is being used.</p> 	<p>Address board</p> <p>Address can be set while the unit is stopped.</p> <p><At delivery></p> 
SW14 Connection No. setting	Rotary switch	<p>This is the switch to be used when the indoor unit is operated with R2 series outdoor unit as a set.</p> 	<p>Address board</p> <p><At delivery></p> 
SW5 Voltage selection	2	<p>If the unit is used at the 230V or 240V area, set the switch to 240V side. If the unit is used at the 220V, set the switch to 220V side.</p> 	<p>Address board</p> <p><At delivery></p> 

7-3. TEST POINT DIAGRAM

7-3-1. Indoor controller board

PCFY-P40VGM-E

PCFY-P63VGM-E

PCFY-P100VGM-E

PCFY-P125VGM-E

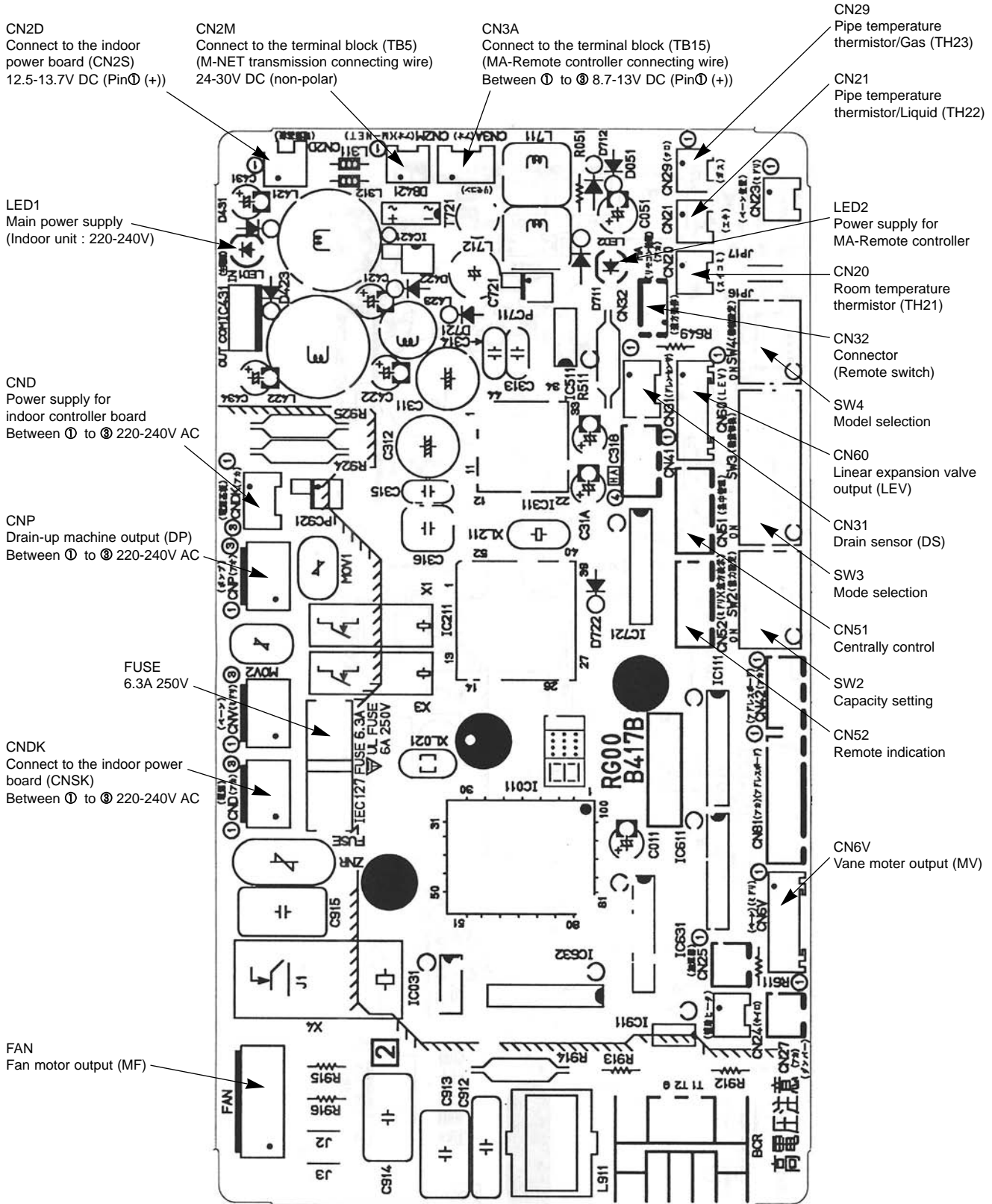

PCFY-P40VGM-E PCFY-P63VGM-E PCFY-P100VGM-E PCFY-P125VGM-E

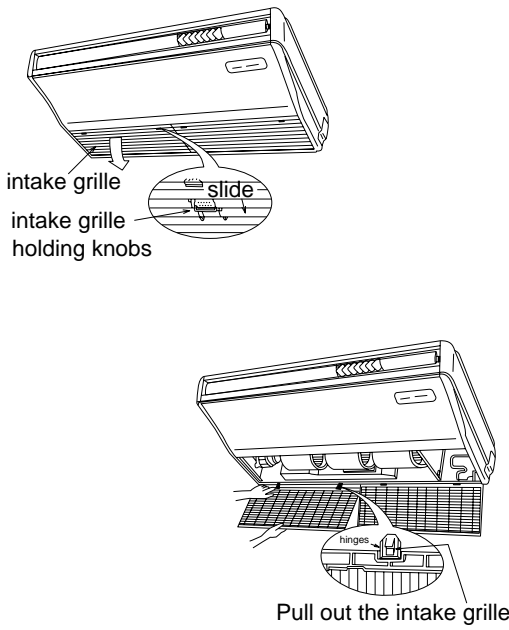
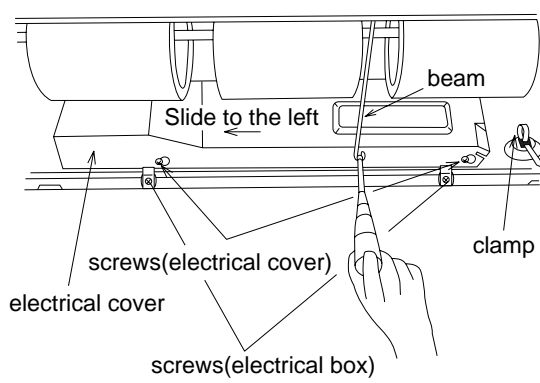
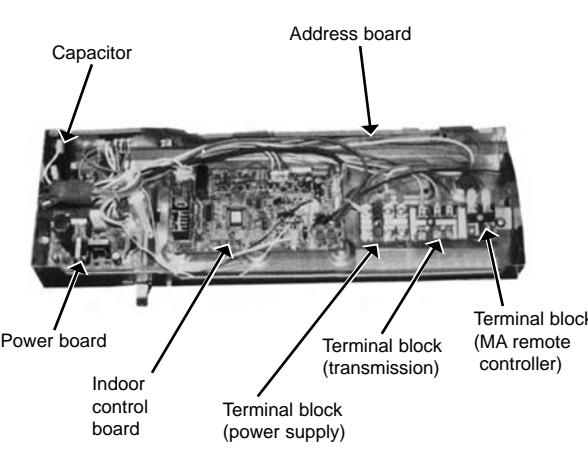
OPERATING PROCEDURE	PHOTOS & ILLUSTRATIONS
<p>1. Removing the air intake grille</p> <ol style="list-style-type: none"> (1) Slide the intake grille holding the knobs at backward to open the intake grille. (2) When the intake grille left open, push the stoppers on the rear hinges (at two locations) to pull out the intake grille. 	<p>Figure 1</p> 
<p>2. Removing the electrical box</p> <ol style="list-style-type: none"> (1) Remove the air intake grille. (2) Remove the screw from the beam and remove the beam. (3) Remove the screws from the electrical cover, and remove the electrical cover. (4) Disconnect the following wires from the indoor control board. <ul style="list-style-type: none"> • Fan motor : FAN • Vane motor : CN6V • Linear expansion valve : CN60 • Room temperature thermistor : CN20 • Liquid pipe temperature thermistor : CN21 • Gas pipe temperature thermistor : CN29 (5) Remove the screws from the electrical box and pull out the electrical box. <p><Electrical parts in the electrical box> Terminal block (for power supply) Terminal block (for transmission) Terminal block (for MA remote controller) Indoor control board Address board Power board Capacitor</p>	<p>Figure 2</p>  <p>Photo 1</p> 

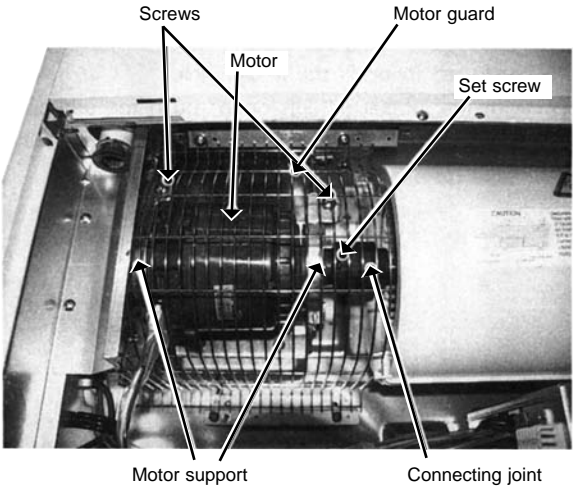
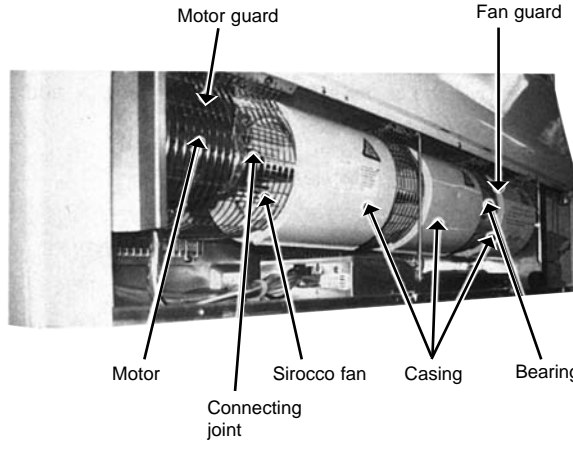
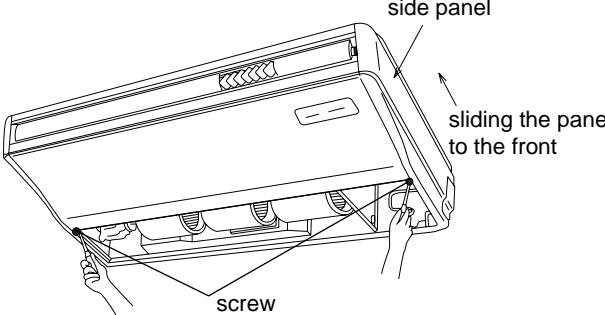

OPERATING PROCEDURE	PHOTOS & ILLUSTRATIONS
<p>3. Removing the fan motor</p> <ol style="list-style-type: none">(1) Remove the air intake grille.(2) Disconnect the fan motor guard.(3) Unscrew screws for removing the motor guard.(4) Unscrew screws for removing the fan guard.(5) Remove the screw for removing the motor support at both left and right side.(6) Loosen the set screws at the fan motor side of the connecting joint.(7) Slide the fan motor to the left side and pull it out.	<p>Photo 2</p>  <p>Labels in Photo 2: Screws, Motor, Motor guard, Set screw, Motor support, Connecting joint.</p>
<p>4. Removing the sirocco fan</p> <ol style="list-style-type: none">(1) Remove the air intake grille.(2) Remove 1 beam.(3) Unscrew screws for removing the motor guard.(4) Unscrew screws for removing the fan guard.(5) Remove the lower casing while pressing the stoppers at upper side of the casing.(6) Loosen the set screws at the connecting joint.(7) Remove the sirocco fan and shaft together by sliding the shaft to the left. <p>(Note) Make sure that the upper side casing is snapped to the fan plate securely with catch.</p>	<p>Photo 3</p>  <p>Labels in Photo 3: Motor guard, Fan guard, Motor, Sirocco fan, Casing, Bearing, Connecting joint.</p>
<p>5. Removing the side panel</p> <ol style="list-style-type: none">(1) Remove the air intake grille.(2) Remove the screw from the side panel, and remove the side panel by sliding the panel to the front.	<p>Figure 3</p>  <p>Labels in Figure 3: side panel, screw, sliding the panel to the front.</p>

OPERATING PROCEDURE

PHOTOS & ILLUSTRATIONS

6. Removing the vane motor

- (1) Remove the air intake.
- (2) Remove the left side panel.
- (3) Remove the relay connector of vane motor.
- (4) Remove the electrical box.
- (5) Remove the screws of vane motor, then remove vane motor.

(Note)

Connect the lead wires and connectors properly and place them in the proper position so that the wires are not pinched by other parts.

Photo 4

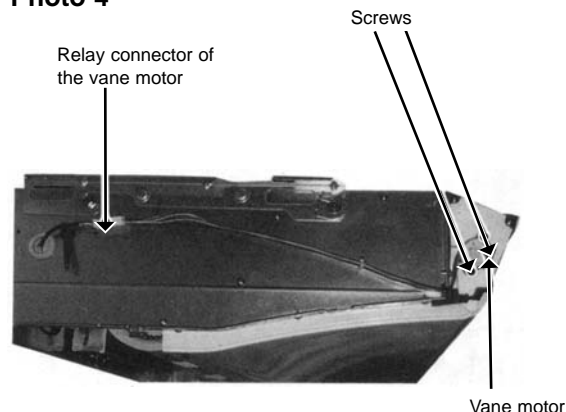

7. Removing the pipe temperature thermistor

- (1) Remove the air intake grille.
- (2) Remove the right side panel.
- (3) Remove the relay connector of the pipe temperature thermistor.
- (4) Remove the screw, and remove the check panel.
- (5) Extract the pipe temperature thermistor from the holder.

<Caution for the installation>

There is a possibility for the short circuit when connector gets wet by water through the thermistor lead wire.

Therefore, lead wire of the pipe temperature thermistor should be trapped as shown in photo 6.

- (6) Gas pipe temperature thermistor is inserted to the holder of the gas pipe (Header)

Photo 5

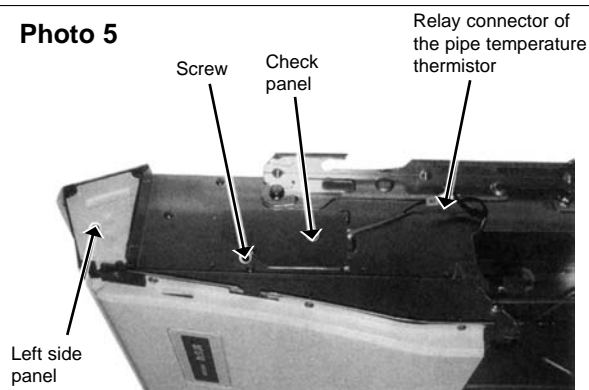

Photo 6

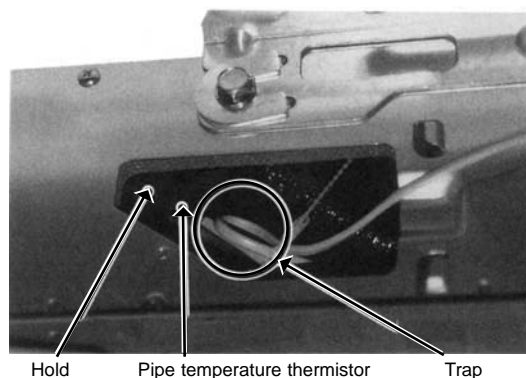
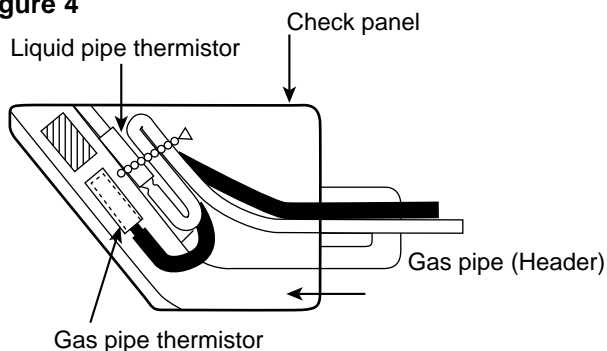

Figure 4



8. Removing the under panel

- (1) Remove the air intake grille.
- (2) Remove the beam.
- (3) Remove the side panel (right and left).
- (4) Unscrew the screws of the under panel, then remove the lower panel.

※ Weight of the lower panel : Approx. 2kg.

Photo 7

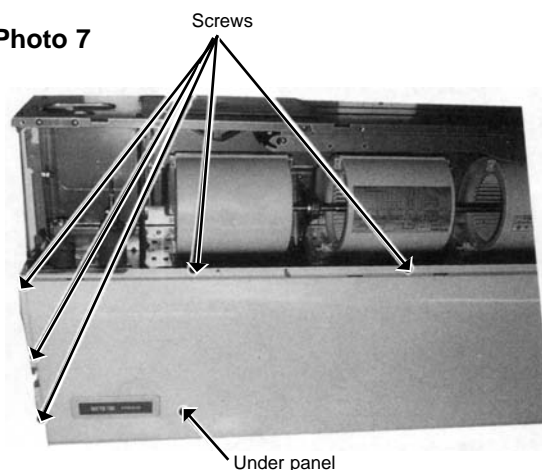



ELECTRICAL PARTS

PCFY-P40VGM-E

PCFY-P63VGM-E

PCFY-P100VGM-E

PCFY-P125VGM-E

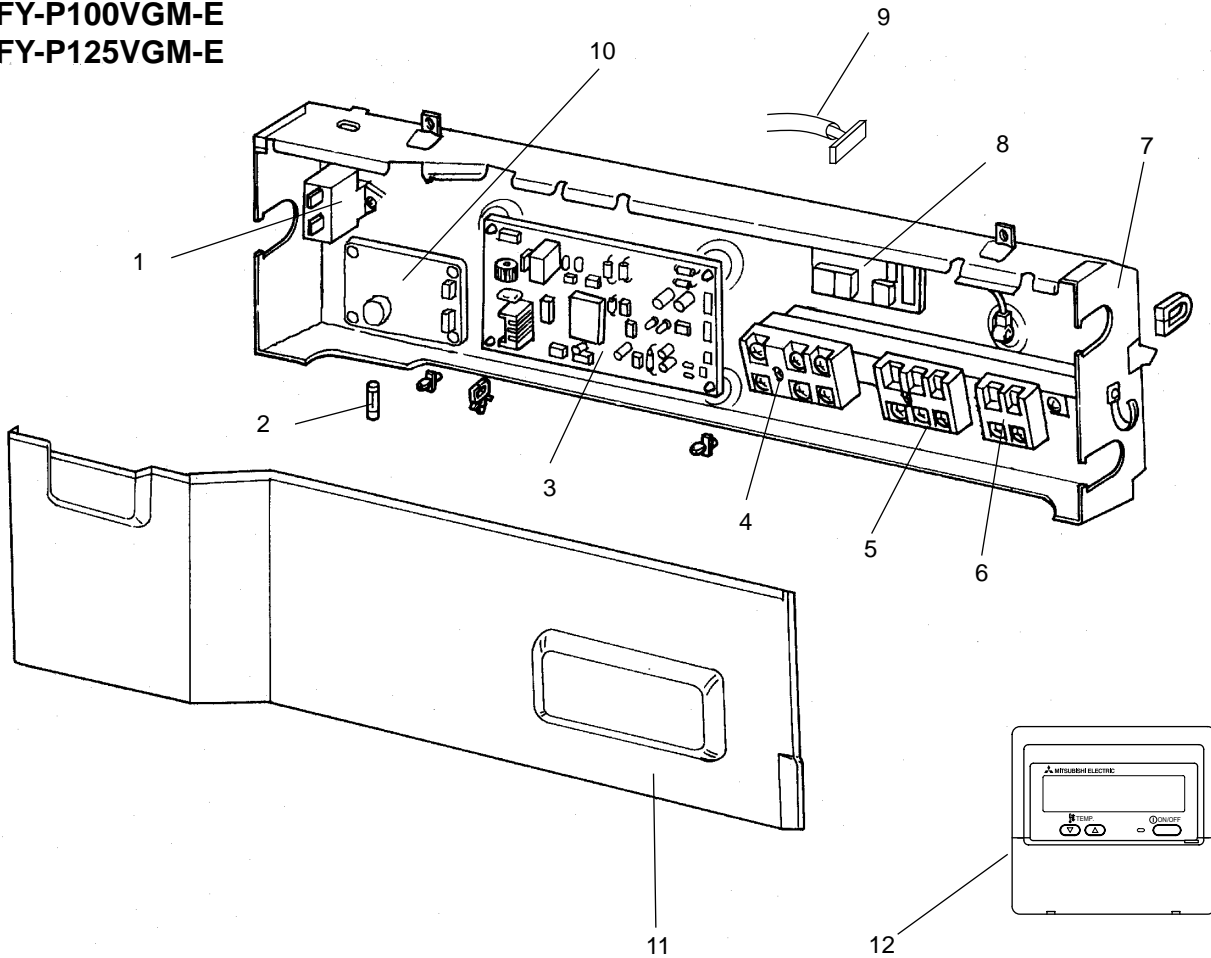

No.	Parts No.	Parts Name	Specifications	Q'ty/set				Remarks (Drawing No.)	Wiring Diagram Symbol	Recom- mended Q'ty	Price	
				PCFY- • VGM-E							Unit	Amount
				P40	P63	P100	P125					
1	R01 30L 255	CAPACITOR	3 μ F 440V	1					C1			
	T7W 39J 255	CAPACITOR	4 μ F 440V		1	1			C1			
	R01 A13 255	CAPACITOR	6 μ F 440V				1		C1			
2	T7W 520 239	FUSE	250V 6.3A	1	1	1	1					
3	T7W E34 310	INDOOR CONTROLLER BOARD		1	1	1	1		I.B			
4	T7W A14 716	TERMINAL BLOCK	3P(L,N,⊕)	1	1	1	1		TB2			
5	T7W E00 716	TERMINAL BLOCK	3P(M1,M2,S)	1	1	1	1		TB5			
6	T7W 515 716	TERMINAL BLOCK	2P(1,2)	1	1	1	1		TB15			
7	—	CONTROL BOX		1	1	1	1	(BG00N015G31)				
8	T7W B01 294	ADDRESS BOARD		1	1	1	1		A.B			
9	R01 05A 304	ADDRESS CABLE		1	1	1	1					
10	R01 E02 313	POWER BOARD		1	1	1	1		P.B			
11	—	BOX COVER		1				(BG02A804G20)				
	—	BOX COVER			1		1	(BG02A804G21)				
	—	BOX COVER				1		(BG02A804G22)				
12	—	REMOTE CONTROLLER	PAR-21MAA	1	1	1	1					

**STRUCTURAL PART
PCFY-P40VGM-E**

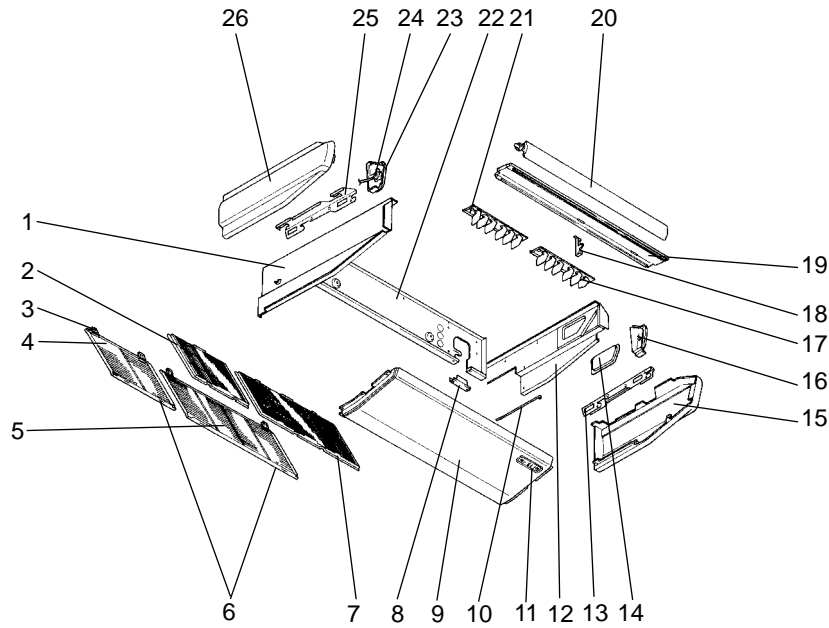

Part number that is circled is not shown in the figure.

No.	Parts No.	Parts Name	Specifications	Q'ty/set PCFY- P40VGM-E	Remarks (Drawing No.)	Wiring Diagram Symbol	Recom- mended Q'ty	Price	
								Unit	Amount
1	R01 57N 666	S.PLATE-L		1					
2	R01 A15 500	L.L FILTER		1					
3	R01 17J 061	GRILLE HINGE		4					
4	R01 18J 691	GRILLE ASSY		1					
5	R01 17J 691	GRILLE ASSY		1					
6	R01 17J 054	GRILLE CATCH		4					
7	R01 A14 500	L.L FILTER		1					
8	—	REAR SUPPORT		1	(BG02H454K01)				
9	R01 17J 669	UNDER PANEL		1					
10	—	BEAM(GA)		2	(BG17H464H08)				
11	T7W E00 070	W.BOARD CASE		1					
12	R01 18J 665	S.PLATE-R		1					
13	R01 17J 808	RIGHT LEG (R)		1					
14	R01 17J 668	SERVICE PANEL		1					
15	R01 17J 661	RIGHT SIDE PANEL		1					
16	R01 17J 067	RIGHT SIDE BOX		1					
17	R01 17J 085	G.V ASSY-6R		1					
18	—	VANE SUPPORT		1	(BG02R321G07)				
19	R01 17J 651	FRONT PANEL		1					
20	R01 17J 002	AUTO VANE		1					
21	R01 18J 086	G.V ASSY-6L		1					
22	R01 A14 676	REAR PANEL		1					
23	R01 17J 068	LEFT SIDE BOX		1					
24	R01 E03 223	VANE MOTOR		1		MV			
25	R01 17J 809	LEFT LEG (L)		1					
26	R01 17J 662	LEFT SIDE PANEL		1					
27	R01 17J 523	JOINT SOCKET		1					

STRUCTURAL PART
PCFY-P63VGM-E
PCFY-P100VGM-E

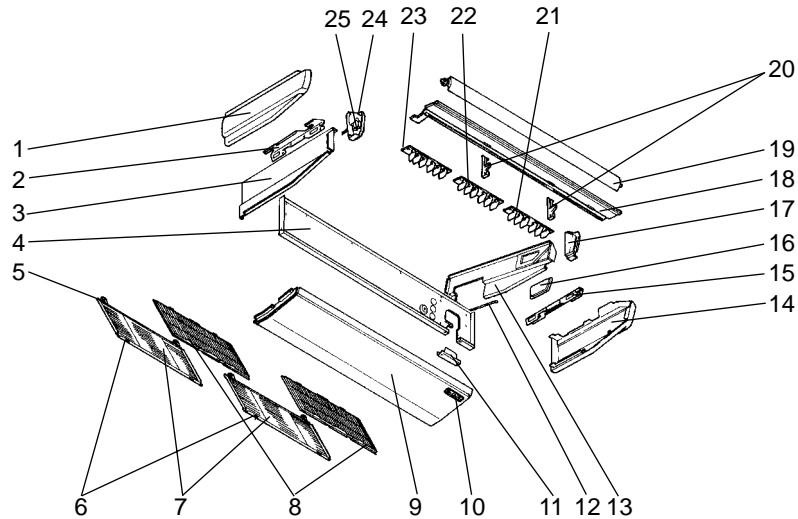

Part number that is circled is not show in the figure.

No.	Parts No.	Parts Name	Specifications	Q'ty/set		Remarks (Drawing No.)	Wiring Diagram Symbol	Recom- mended Q'ty	Price	
				PCFY- P63	VGM-E P100				Unit	Amount
1	R01 17J 662	LEFT SIDE PANEL		1						
	R01 35J 662	LEFT SIDE PANEL			1					
2	R01 17J 809	LEFT LEG		1	1					
3	R01 57N 666	S.PLATE-L		1						
	R01 35J 666	S.PLATE-L			1					
4	R01 A15 676	REAR PANEL		1						
	R01 A16 676	REAR PANEL			1					
5	R01 17J 061	GRILLE HINGE		4	4					
6	R01 17J 054	GRILLE CATCH		4	4					
7	R01 17J 691	GRILLE ASSY		2	2					
8	R01 A14 500	L.L FILTER		2	2					
9	R01 29J 669	UNDER PANEL		1	1					
10	T7W E00 070	W.BOARD CASE		1	1					
11	—	REAR SUPPORT		1	1	(BG02H454K01)				
12	—	BEAM (GA)		2	2	(BG17H464H08)				
13	R01 18J 665	S.PLATE-R		1						
	R01 E00 665	S.PLATE-R			1					
14	R01 17J 661	RIGHT SIDE PANEL		1						
	R01 35J 661	RIGHT SIDE PANEL			1					
15	R01 17J 808	RIGHT LEG		1	1					
16	R01 17J 668	SERVICE PANEL		1						
	R01 18J 668	SERVICE PANEL			1					
17	R01 17J 067	RIGHT SIDE BOX		1						
	R01 35J 067	RIGHT SIDE BOX			1					
18	R01 29J 651	FRONT PANEL		1						
	R01 36J 651	FRONT PANEL			1					
19	R01 29J 002	AUTO VANE		1						
	R01 E03 002	AUTO VANE			1					
20	—	VANE SUPPORT		2		(BG02R321G07)				
	—	VANE SUPPORT			2	(BG02R805G05)				
21	R01 17J 085	G.V ASSY-6R		1						
	R01 37J 085	G.V ASSY-6R			1					
22	R01 29J 087	G.V ASSY-6C		1						
	R01 37J 087	G.V ASSY-6C			1					
23	R01 18J 086	G.V ASSY-6L		1						
	R01 37J 086	G.V ASSY-6L			1					
24	R01 17J 068	LEFT SIDE BOX		1						
	R01 E00 068	LEFT SIDE BOX			1					
25	R01 29J 223	VANE MOTOR		1			MV			
	R01 35J 223	VANE MOTOR			1		MV			
(26)	R01 17J 523	JOINT SOCKET		1	1					

STRUCTURAL PART
PCFY-P125VGM-E

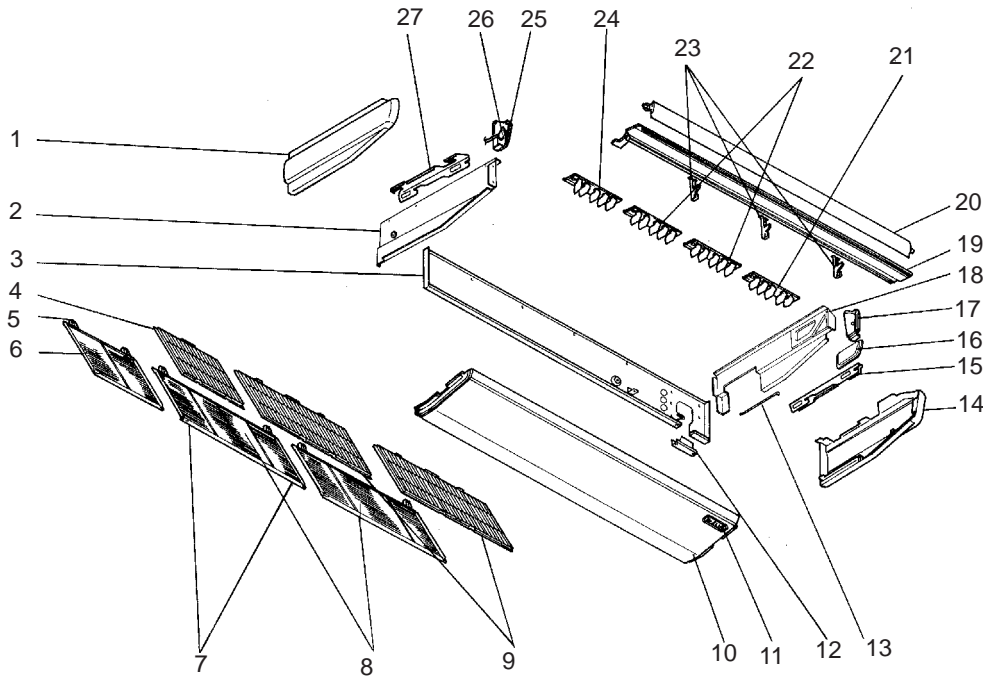

Part number that is circled is not shown in the figure.

No.	Parts No.	Parts Name	Specifications	Q'ty/set	Remarks (Drawing No.)	Wiring Diagram Symbol	Recom- mended Q'ty	Price	
				PCFY- P125VGM-E				Unit	Amount
1	R01 35J 662	LEFT SIDE PANEL		1					
2	R01 35J 666	S.PLATE-L		1					
3	R01 A17 676	REAR PANEL		1					
4	R01 A15 500	L.L FILTER		1					
5	R01 17J 061	GRILLE HINGE		6					
6	R01 18J 691	GRILLE ASSY		1					
7	R01 17J 054	GRILLE CATCH		6					
8	R01 17J 691	GRILLE ASSY		2					
9	R01 A14 500	L.L FILTER		2					
10	R01 41J 669	UNDER PANEL		1					
11	T7W E00 070	W.BOARD CASE		1					
12	—	REAR SUPPORT		1	(BG02H454K01)				
13	—	BEAM(GA)		3	(BG17H464H08)				
14	R01 35J 661	RIGHT SIDE PANEL		1					
15	R01 17J 808	RIGHT LEG		1					
16	R01 18J 668	SERVICE PANEL		1					
17	R01 35J 067	RIGHT SIDE BOX		1					
18	R01 E00 665	S.PLATE-R		1					
19	R01 41J 651	FRONT PANEL		1					
20	R01 E04 002	AUTO VANE		1					
21	R01 41J 085	G.V ASSY-5R		1					
22	R01 43J 087	G.V ASSY-5C		2					
23	—	VANE SUPPORT		3	(BG02R805G05)				
24	R01 42J 086	G.V ASSY-5L		1					
25	R01 E00 068	LEFT SIDE BOX		1					
26	R01 35J 223	VANE MOTOR		1		MV			
27	R01 17J 809	LEFT LEG		1					
28	R01 17J 523	JOINT SOCKET		1					

**FAN AND HEATER PARTS
PCFY-P40VGM-E**

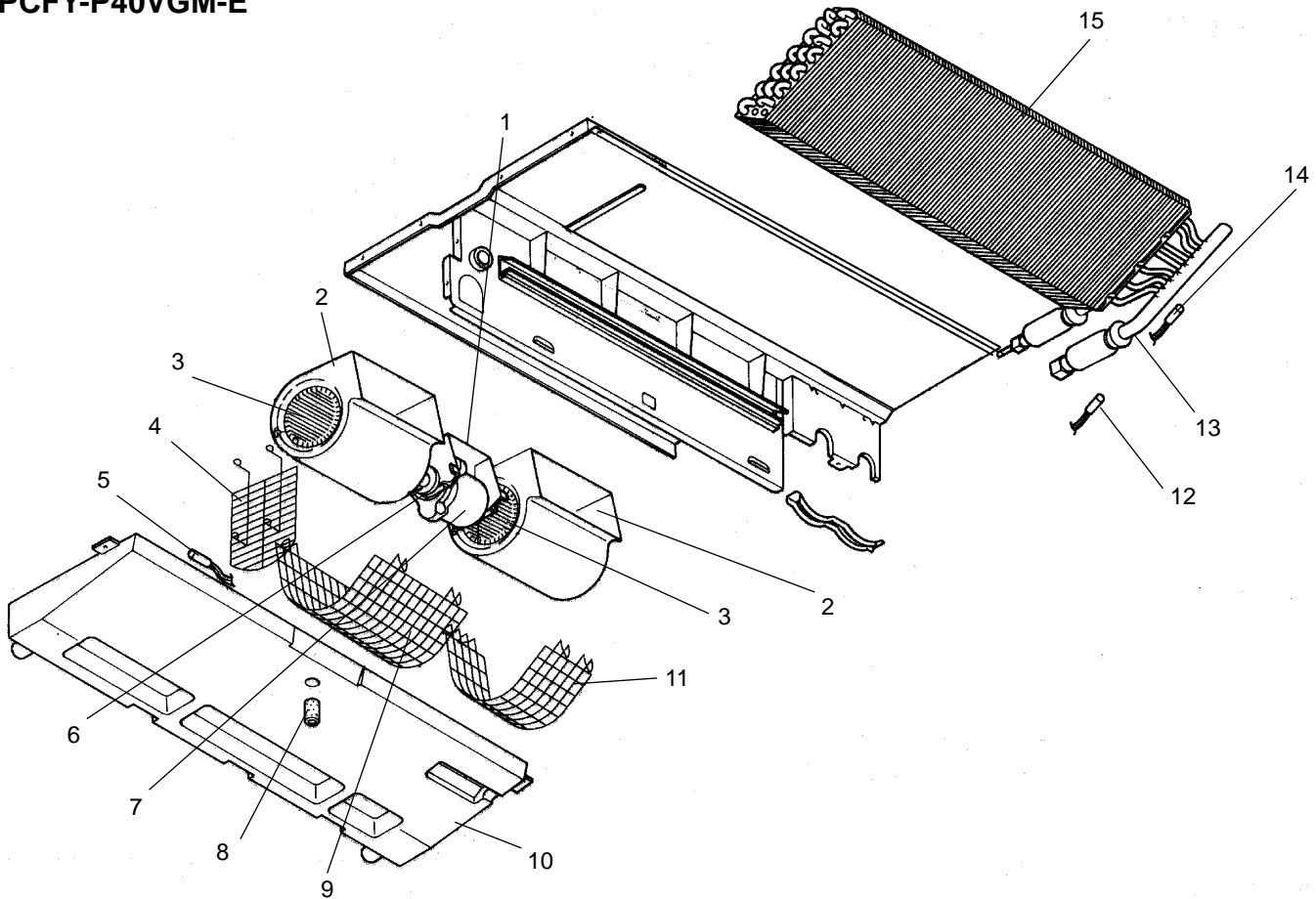

Part number that is circled is not shown in the figure.

No.	Parts No.	Parts Name	Specifications	Q'ty/set	Remarks (Drawing No.)	Wiring Diagram Symbol	Recom- mended Q'ty	Price	
				PCFY- P40VGM-E				Unit	Amount
1	R01 17J 130	MOTOR LEG		1					
2	T7W B06 110	CASING		2					
3	R01 17J 114	SIROCCO FAN		2					
4	T7W 19J 675	FAN GUARD		1					
5	R01 E26 202	ROOM TEMPERATURE THERMISTOR		1		TH21			
6	R01 43E 126	PIECE (MOTOR)		1	2pcs/set				
7	T7W 23J 762	FAN MOTOR	D09B4P54MS	1		MF			
8	R01 17J 524	DRAIN PLUG		1					
9	T7W 17J 675	FAN GUARD		1					
10	R01 A14 529	DRAIN PAN ASSY		1					
11	T7W 18J 675	FAN GUARD		1					
12	R01 E27 202	LIQUID PIPE TEMPERATURE THERMISTOR		1		TH22			
13	R01 E60 401	LINEAR EXPANSION VALVE		1		LEV			
14	R01 17J 202	GAS PIPE TEMPERATURE THERMISTOR		1		TH23			
15	R01 H47 480	HEAT EXCHANGER		1					
⑬	T7W E00 072	DRAIN HOSE COVER		1					

FAN AND HEATER PARTS
PCFY-P63VGM-E
PCFY-P100VGM-E

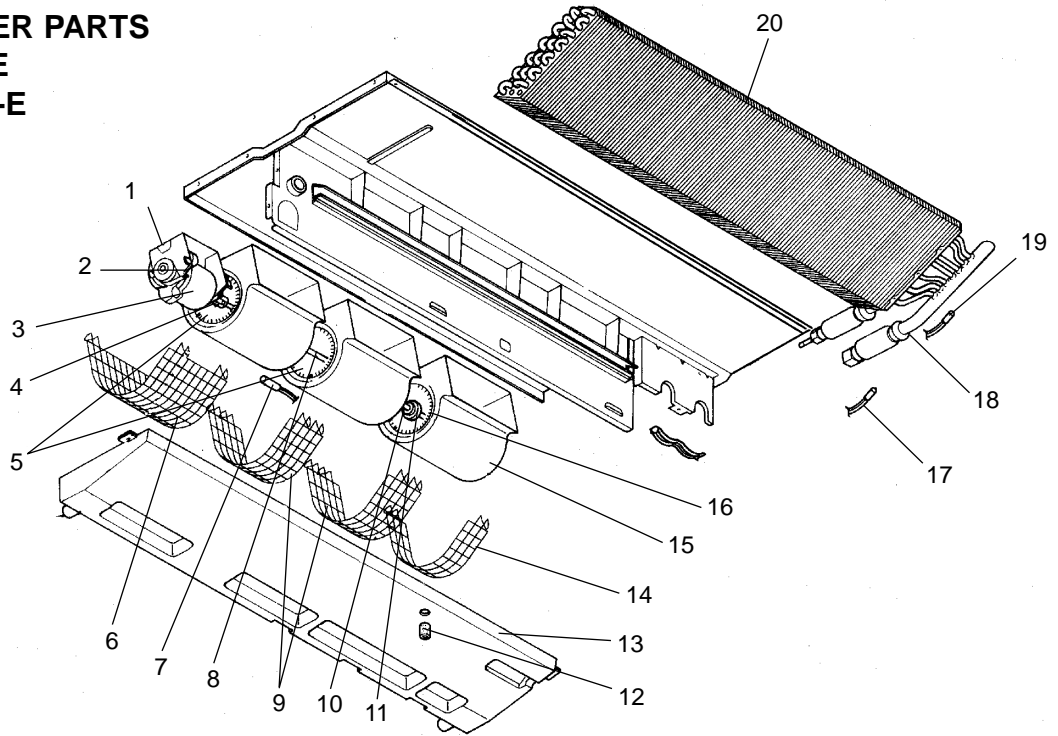

Part number that is circled is not shown in the figure.

No.	Parts No.	Parts Name	Specifications	Q'ty/set		Remarks (Drawing No.)	Wiring Diagram Symbol	Recom- mended Q'ty	Price	
				PCFY- P63	VGM-E P100				Unit	Amount
1	R01 29J 130	MOTOR LEG		1						
	R01 35J 130	MOTOR LEG			1					
2	R01 43E 126	PIECE(MOTOR)		1	1	2pcs/set				
3	T7W 30J 762	FAN MOTOR	D09C4P70MS	1			MF			
	T7W 39J 762	FAN MOTOR	D10B4P90MS		1		MF			
4	R01 700 116	FAN JOINT		1	1					
5	R01 29J 114	SIROCCO FAN		2						
	R01 35J 114	SIROCCO FAN			2					
6	T7W 20J 675	FAN GUARD		1						
	T7W 22J 675	FAN GUARD			1					
7	R01 E26 202	ROOM TEMPERATURE THERMISTOR		1	1		TH21			
8	R01 29J 100	SHAFT		1	1					
9	T7W 21J 675	FAN GUARD		2						
	T7W 23J 675	FAN GUARD			2					
10	R01 E00 103	SLEEVE BEARING		1	1					
11	R01 29J 145	BEARING SUPPORT		1						
	R01 35J 145	BEARING SUPPORT			1					
12	R01 17J 524	DRAIN PLUG		1	1					
13	R01 A15 529	DRAIN PAN ASSY		1						
	R01 A16 529	DRAIN PAN ASSY			1					
14	T7W 18J 675	FAN GUARD		1						
	T7W 24J 675	FAN GUARD			1					
15	T7W B06 110	CASING		3						
	T7W B07 110	CASING			3					
16	R01 33J 114	SIROCCO FAN		1						
	R01 39J 114	SIROCCO FAN			1					
17	R01 E27 202	LIQUID PIPE TEMPERATURE THERMISTOR		1	1		TH22			
18	R01 E60 401	LINEAR EXPANSION VALVE		1			LEV			
	R01 E61 401	LINEAR EXPANSION VALVE			1		LEV			
19	R01 17J 202	GAS PIPE TEMPERATURE THERMISTOR		1	1		TH23			
20	R01 H49 480	HEAT EXCHANGER		1						
	R01 H52 480	HEAT EXCHANGER			1					
②1	T7W E00 072	DRAIN HOSE COVER		1	1					

FAN AND HEATER PARTS PCFY-P125VGM-E

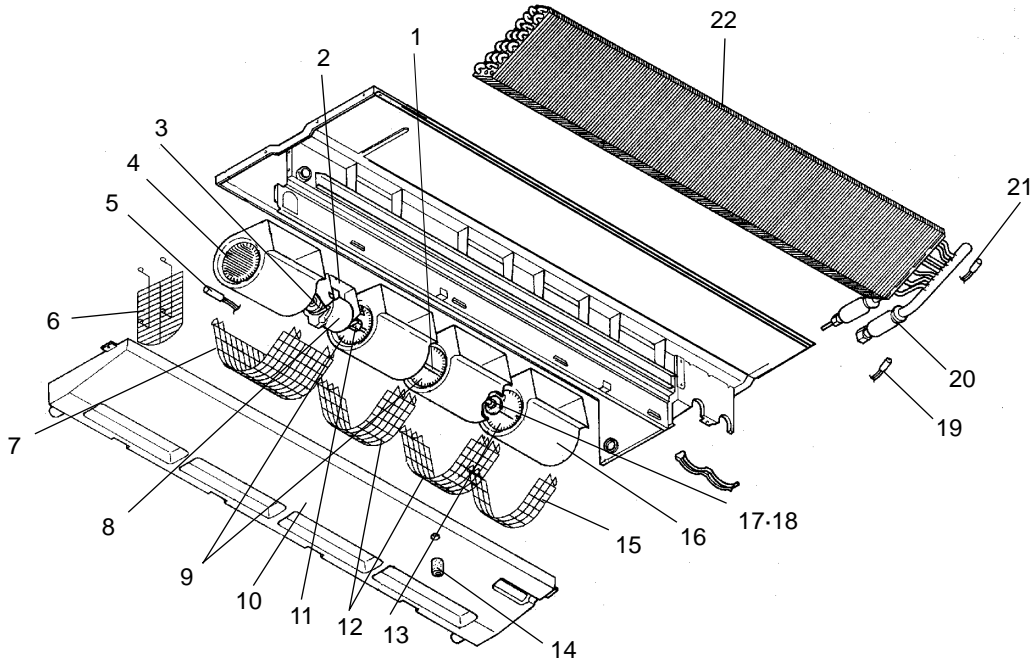

Part number that is circled is not shown in the figure.

No.	Parts No.	Parts Name	Specifications	Q'ty/set	Remarks (Drawing No.)	Wiring Diagram Symbol	Recom- mended Q'ty	Price	
				PCFY- P125VGM-E				Unit	Amount
1	R01 29J 100	SHAFT		1					
2	R01 41J 130	MOTOR LEG		1					
3	R01 43E 126	PIECE (MOTOR)		1	2pcs/set				
4	R01 41J 114	SIROCCO FAN		1					
5	R01 E26 202	ROOM TEMPERATURE THERMISTOR		1		TH21			
6	T7W 26J 675	FAN GUARD		1					
7	T7W 25J 675	FAN GUARD		1					
8	T7W 43J 762	FAN MOTOR	D10B4P150MS	1		MF			
9	R01 35J 114	SIROCCO FAN		2					
10	R01 A17 529	DRAIN PAN ASSY		1					
11	R01 700 116	FAN JOINT		1					
12	T7W 23J 675	FAN GUARD		2					
13	R01 39J 114	SIROCCO FAN		1					
14	R01 17J 524	DRAIN PLUG		1					
15	T7W 24J 675	FAN GUARD		1					
16	T7W B07 110	CASING		4					
17	R01 E00 103	SLEEVE BEARING		1					
18	R01 35J 145	BEARING SUPPORT		1					
19	R01 E27 202	LIQUID PIPE TEMPERATURE THERMISTOR		1		TH22			
20	R01 E61 401	LINEAR EXPANSION VALVE		1		LEV			
21	R01 17J 202	GAS PIPE TEMPERATURE THERMISTOR		1		TH23			
22	R01 H53 480	HEAT EXCHANGER		1					
23	T7W E00 072	DRAIN HOSE COVER		1					

10

RoHS PARTS LIST

ELECTRICAL PARTS

PCFY-P40VGM-E

PCFY-P63VGM-E

PCFY-P100VGM-E

PCFY-P125VGM-E

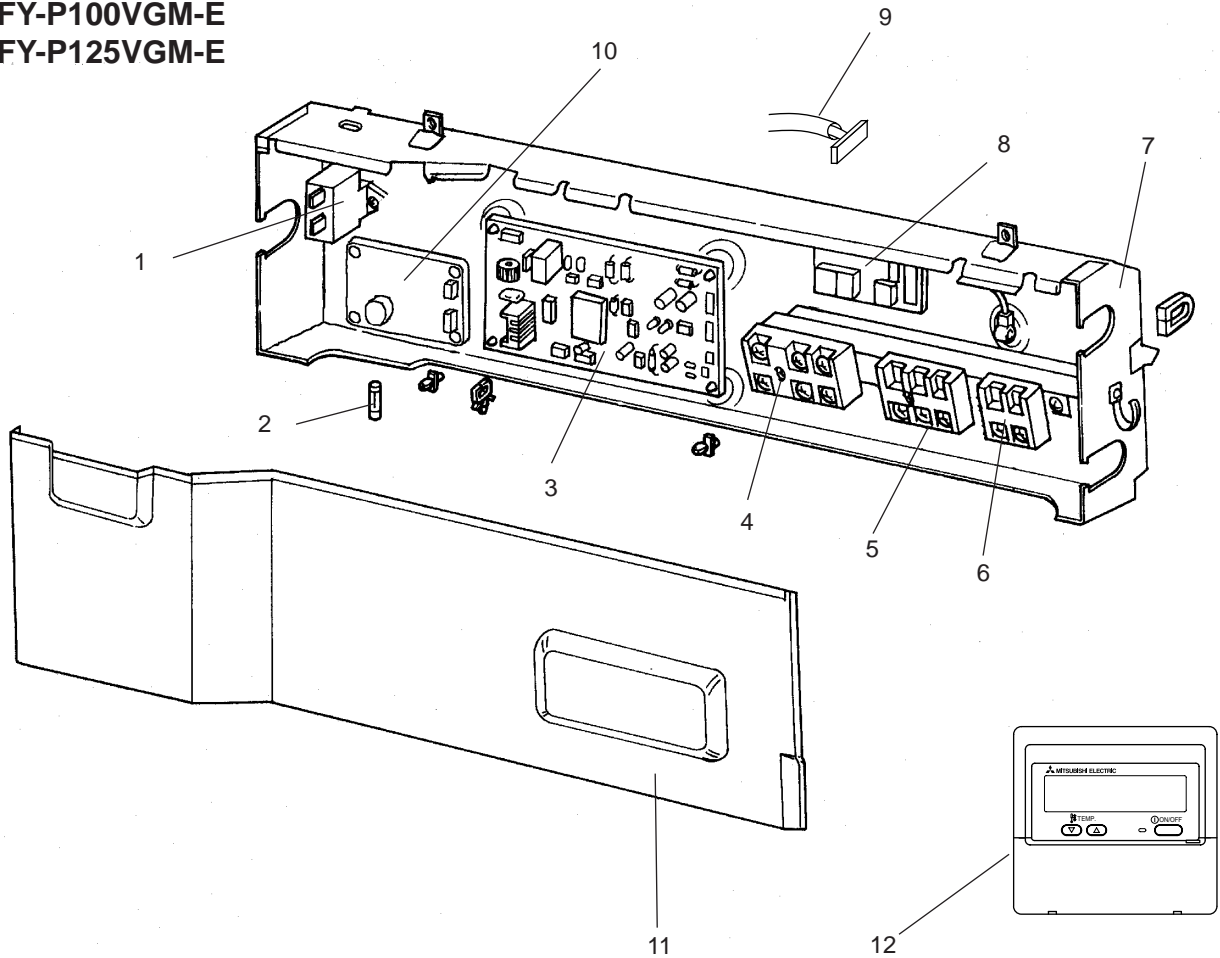

No.	RoHS	Parts No.	Parts Name	Specifications	Q'ty/set				Remarks (Drawing No.)	Wiring Diagram Symbol	Recom- mended Q'ty	Price	
					PCFY- • VGM-E							Unit	Amount
					P40	P63	P100	P125					
1	G	R01 A15 255	CAPACITOR	3 μ F 440V	1					C1			
	G	T7W E13 255	CAPACITOR	4 μ F 440V		1	1			C1			
	G	R01 A14 255	CAPACITOR	6 μ F 440V				1		C1			
2	G	R01 E06 239	FUSE	250V 6.3A	1	1	1	1					
3	G	T7W E53 310	INDOOR CONTROLLER BOARD		1	1	1	1		I.B			
4	G	T7W E32 716	TERMINAL BLOCK	3P(L,N,⊕)	1	1	1	1		TB2			
5	G	T7W E35 716	TERMINAL BLOCK	3P(M1,M2,S)	1	1	1	1		TB5			
6	G	T7W E36 716	TERMINAL BLOCK	2P(1,2)	1	1	1	1		TB15			
7	G	—	CONTROL BOX		1	1	1	1	(BG00N015G31)				
8	G	T7W E01 294	ADDRESS BOARD		1	1	1	1		A.B			
9	G	R01 A01 304	ADDRESS CABLE		1	1	1	1					
10	G	R01 E38 313	POWER BOARD		1	1	1	1		P.B			
11	G	—	BOX COVER		1				(BG02A804G20)				
	G	—	BOX COVER			1		1	(BG02A804G21)				
	G	—	BOX COVER				1		(BG02A804G22)				
12	G	—	REMOTE CONTROLLER	PAR-21MAA	1	1	1	1					

**STRUCTURAL PART
PCFY-P40VGM-E**

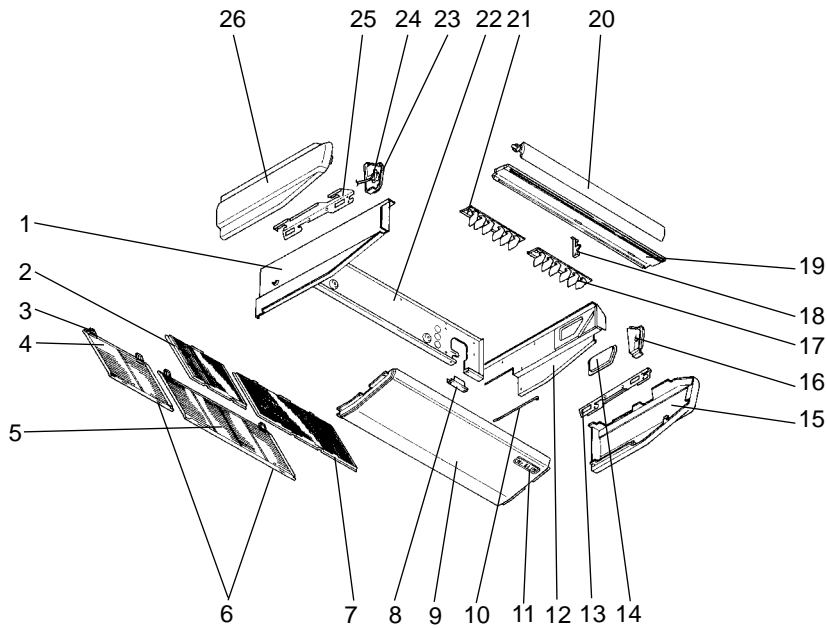

Part number that is circled is not shown in the figure.

No.	RoHS	Parts No.	Parts Name	Specifications	Q'ty/set PCFY- P40VGM-E	Remarks (Drawing No.)	Wiring Diagram Symbol	Recom- mended Q'ty	Price	
									Unit	Amount
1	G	R01 E00 666	S.PLATE-L		1					
2	G	R01 A30 500	L.L FILTER		1					
3	G	R01 18J 061	GRILLE HINGE		4					
4	G	R01 20J 691	GRILLE ASSY		1					
5	G	R01 19J 691	GRILLE ASSY		1					
6	G	R01 19J 054	GRILLE CATCH		4					
7	G	R01 A29 500	L.L FILTER		1					
8	G	—	REAR SUPPORT		1	(BG02H454K01)				
9	G	R01 31J 669	UNDER PANEL		1					
10	G	—	BEAM(GA)		2	(BG17H464H08)				
11	G	T7W E03 070	W.BOARD CASE		1					
12	G	R01 19J 665	S.PLATE-R		1					
13	G	R01 18J 808	RIGHT LEG (R)		1					
14	G	R01 19J 668	SERVICE PANEL		1					
15	G	R01 18J 661	RIGHT SIDE PANEL		1					
16	G	R01 18J 067	RIGHT SIDE BOX		1					
17	G	R01 40J 085	G.V ASSY-6R		1					
18	G	—	VANE SUPPORT		1	(BG02R321G07)				
19	G	R01 37J 651	FRONT PANEL		1					
20	G	R01 31J 002	AUTO VANE		1					
21	G	R01 40J 086	G.V ASSY-6L		1					
22	G	R01 A18 676	REAR PANEL		1					
23	G	R01 18J 068	LEFT SIDE BOX		1					
24	G	R01 E11 223	VANE MOTOR		1		MV			
25	G	R01 18J 809	LEFT LEG (L)		1					
26	G	R01 18J 662	LEFT SIDE PANEL		1					
27	G	R01 18J 523	JOINT SOCKET		1					

STRUCTURAL PART
PCFY-P63VGM-E
PCFY-P100VGM-E

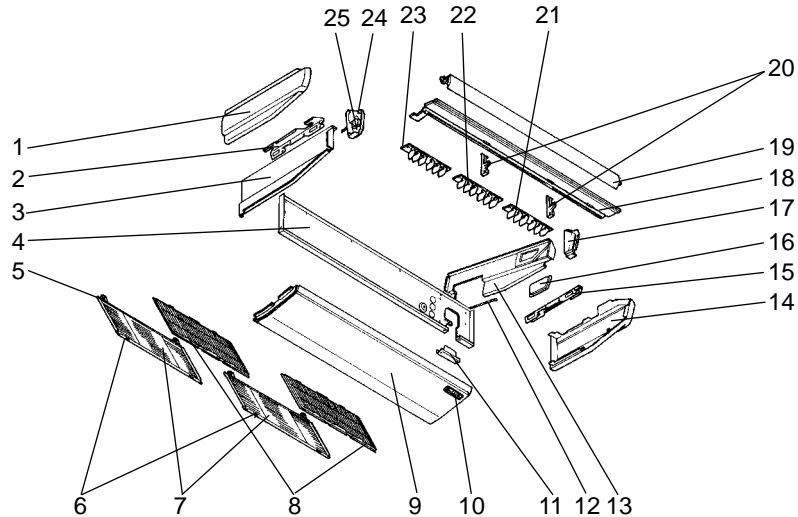

Part number that is circled is not show in the figure.

No.	RoHS	Parts No.	Parts Name	Specifications	Q'ty/set		Remarks (Drawing No.)	Wiring Diagram Symbol	Recom- mended Q'ty	Price	
					PCFY- P63	VGM-E P100				Unit	Amount
1	G	R01 18J 662	LEFT SIDE PANEL		1						
	G	R01 36J 662	LEFT SIDE PANEL			1					
2	G	R01 18J 809	LEFT LEG		1	1					
3	G	R01 E00 666	S.PLATE-L		1						
	G	R01 E01 666	S.PLATE-L			1					
4	G	R01 30J 676	REAR PANEL		1						
	G	R01 A21 676	REAR PANEL			1					
5	G	R01 18J 061	GRILLE HINGE		4	4					
	G	R01 19J 054	GRILLE CATCH		4	4					
7	G	R01 19J 691	GRILLE ASSY		2	2					
8	G	R01 A29 500	L.L FILTER		2	2					
9	G	R01 30J 669	UNDER PANEL		1	1					
10	G	T7W E03 070	W.BOARD CASE		1	1					
11		—	REAR SUPPORT		1	1	(BG02H454K01)				
12		—	BEAM (GA)		2	2	(BG17H464H08)				
13	G	R01 19J 665	S.PLATE-R		1						
	G	R01 E01 665	S.PLATE-R			1					
14	G	R01 18J 661	RIGHT SIDE PANEL		1						
	G	R01 36J 661	RIGHT SIDE PANEL			1					
15	G	R01 18J 808	RIGHT LEG		1	1					
16	G	R01 19J 668	SERVICE PANEL		1						
	G	R01 20J 668	SERVICE PANEL			1					
17	G	R01 18J 067	RIGHT SIDE BOX		1						
	G	R01 36J 067	RIGHT SIDE BOX			1					
18	G	R01 30J 651	FRONT PANEL		1						
	G	R01 38J 651	FRONT PANEL			1					
19	G	R01 30J 002	AUTO VANE		1						
	G	R01 E14 002	AUTO VANE			1					
20		—	VANE SUPPORT		2		(BG02R321G07)				
		—	VANE SUPPORT			2	(BG02R805G05)				
21	G	R01 40J 085	G.V ASSY-6R		1						
	G	R01 38J 085	G.V ASSY-6R			1					
22	G	R01 40J 087	G.V ASSY-6C		1						
	G	R01 38J 087	G.V ASSY-6C			1					
23	G	R01 40J 086	G.V ASSY-6L		1						
	G	R01 38J 086	G.V ASSY-6L			1					
24	G	R01 18J 068	LEFT SIDE BOX		1						
	G	R01 E01 068	LEFT SIDE BOX			1					
25	G	R01 E10 223	VANE MOTOR		1			MV			
	G	R01 E12 223	VANE MOTOR			1		MV			
26	G	R01 18J 523	JOINT SOCKET		1	1					

STRUCTURAL PART
PCFY-P125VGM-E

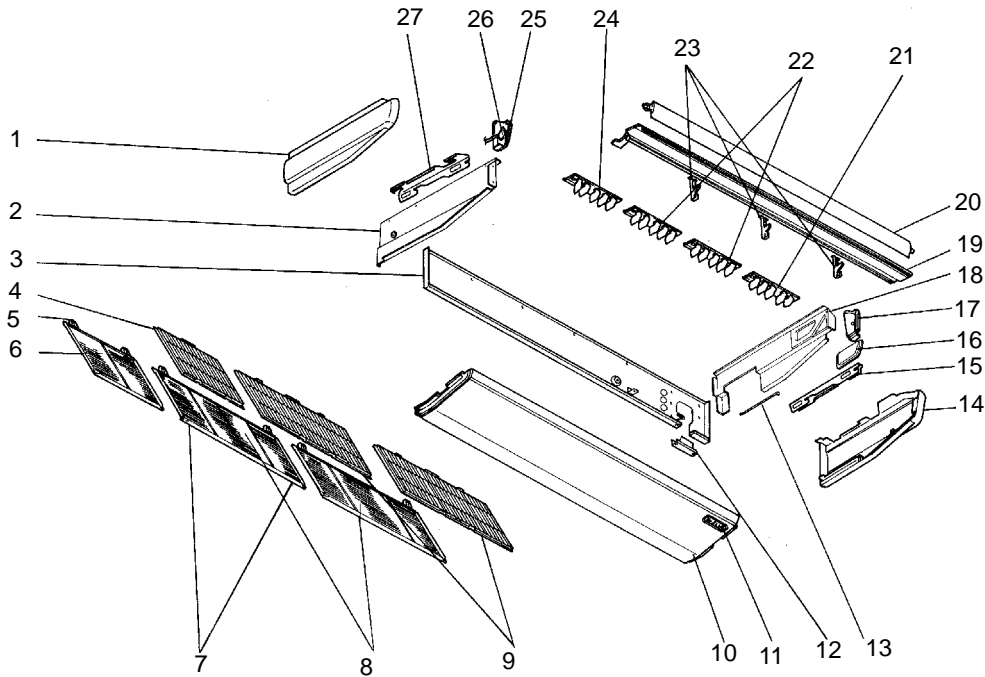

Part number that is circled is not shown in the figure.

No.	RoHS	Parts No.	Parts Name	Specifications	Q'ty/set PCFY- P125VGM-E	Remarks (Drawing No.)	Wiring Diagram Symbol	Recom- mended Q'ty	Price	
									Unit	Amount
1	G	R01 36J 662	LEFT SIDE PANEL		1					
2	G	R01 E01 666	S.PLATE-L		1					
3	G	R01 A19 676	REAR PANEL		1					
4	G	R01 A30 500	L.L FILTER		1					
5	G	R01 18J 061	GRILLE HINGE		6					
6	G	R01 20J 691	GRILLE ASSY		1					
7	G	R01 19J 054	GRILLE CATCH		6					
8	G	R01 19J 691	GRILLE ASSY		2					
9	G	R01 A29 500	L.L FILTER		2					
10	G	R01 32J 669	UNDER PANEL		1					
11	G	T7W E03 070	W.BOARD CASE		1					
12		—	REAR SUPPORT		1	(BG02H454K01)				
13		—	BEAM(GA)		3	(BG17H464H08)				
14	G	R01 36J 661	RIGHT SIDE PANEL		1					
15	G	R01 18J 808	RIGHT LEG		1					
16	G	R01 20J 668	SERVICE PANEL		1					
17	G	R01 36J 067	RIGHT SIDE BOX		1					
18	G	R01 E01 665	S.PLATE-R		1					
19	G	R01 39J 651	FRONT PANEL		1					
20	G	R01 E15 002	AUTO VANE		1					
21	G	R01 39J 085	G.V ASSY-5R		1					
22	G	R01 39J 087	G.V ASSY-5C		2					
23	G	—	VANE SUPPORT		3	(BG02R805G05)				
24	G	R01 39J 086	G.V ASSY-5L		1					
25	G	R01 E01 068	LEFT SIDE BOX		1					
26	G	R01 E12 223	VANE MOTOR		1		MV			
27	G	R01 18J 809	LEFT LEG		1					
28	G	R01 18J 523	JOINT SOCKET		1					

FAN AND HEATER PARTS PCFY-P40VGM-E

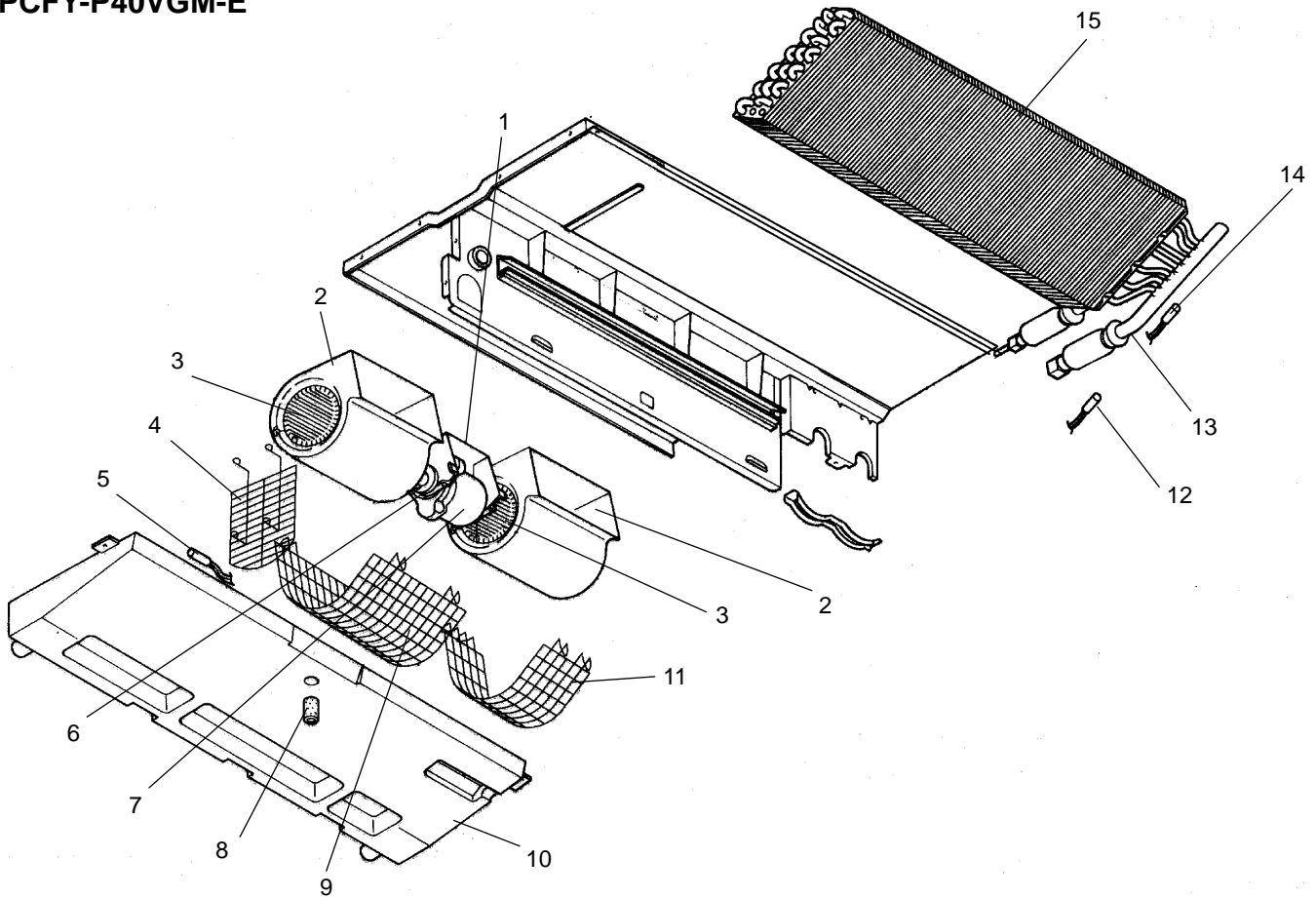

Part number that is circled is not shown in the figure.

No.	RoHS	Parts No.	Parts Name	Specifications	Q'ty/set PCFY- P40VGM-E	Remarks (Drawing No.)	Wiring Diagram Symbol	Recom- mended Q'ty	Price	
									Unit	Amount
1	G	R01 31J 130	MOTOR LEG		1					
2	G	R01 18J 110	CASING		2					
3	G	R01 E16 114	SIROCCO FAN		2					
4	G	T7W 31J 675	FAN GUARD		1					
5	G	R01 H08 202	ROOM TEMPERATURE THERMISTOR		1		TH21			
6	G	R01 45E 126	PIECE (MOTOR)		1	2pcs/set				
7	G	R01 18J 220	FAN MOTOR	D09B4P54MS	1		MF			
8	G	R01 18J 524	DRAIN PLUG		1					
9	G	T7W 30J 675	FAN GUARD		1					
10	G	R01 E27 529	DRAIN PAN ASSY		1					
11	G	T7W 29J 675	FAN GUARD		1					
12	G	R01 H10 202	LIQUID PIPE TEMPERATURE THERMISTOR		1		TH22			
13	G	R01 H02 401	LINEAR EXPANSION VALVE		1		LEV			
14	G	R01 H09 202	GAS PIPE TEMPERATURE THERMISTOR		1		TH23			
15	G	R01 J20 480	HEAT EXCHANGER		1					
16	G	T7W E01 072	DRAIN HOSE COVER		1					

FAN AND HEATER PARTS
PCFY-P63VGM-E
PCFY-P100VGM-E

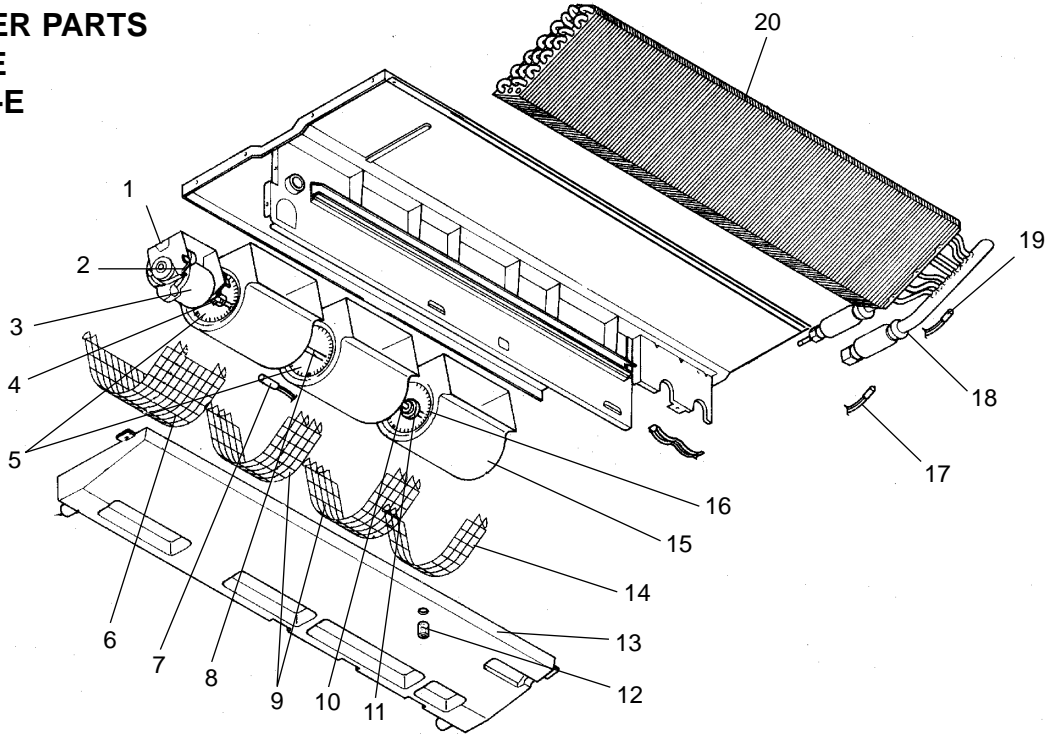

Part number that is circled is not shown in the figure.

No.	RoHS	Parts No.	Parts Name	Specifications	Q'ty/set		Remarks (Drawing No.)	Wiring Diagram Symbol	Recom- mended Q'ty	Price	
					PCFY- P63	VGM-E P100				Unit	Amount
1	G	R01 30J 130	MOTOR LEG		1						
	G	R01 32J 130	MOTOR LEG			1					
2	G	R01 45E 126	PIECE(MOTOR)		1	1	2pcs/set				
3	G	T7W 40J 762	FAN MOTOR	D09C4P70MS	1			MF			
	G	R01 19J 220	FAN MOTOR	D10B4P90MS		1		MF			
4	G	R01 800 116	FAN JOINT		1	1					
5	G	R01 E17 114	SIROCCO FAN		2						
	G	R01 E19 114	SIROCCO FAN			2					
6	G	T7W 27J 675	FAN GUARD		1						
	G	T7W 32J 675	FAN GUARD			1					
7	G	R01 H08 202	ROOM TEMPERATURE THERMISTOR		1	1		TH21			
8	G	R01 30J 100	SHAFT		1	1					
9	G	T7W 28J 675	FAN GUARD		2						
	G	T7W 34J 675	FAN GUARD			2					
10	G	R01 E02 103	SLEEVE BEARING		1	1					
11	G	R01 30J 145	BEARING SUPPORT		1						
	G	R01 36J 145	BEARING SUPPORT			1					
12	G	R01 18J 524	DRAIN PLUG		1	1					
13	G	R01 A18 529	DRAIN PAN ASSY		1						
	G	R01 E28 529	DRAIN PAN ASSY			1					
14	G	T7W 29J 675	FAN GUARD		1						
	G	T7W 35J 675	FAN GUARD			1					
15	G	R01 18J 110	CASING		3						
	G	R01 19J 110	CASING			3					
16	G	R01 E15 114	SIROCCO FAN		1						
	G	R01 E20 114	SIROCCO FAN			1					
17	G	R01 H10 202	LIQUID PIPE TEMPERATURE THERMISTOR		1	1		TH22			
18	G	R01 H02 401	LINEAR EXPANSION VALVE		1			LEV			
	G	R01 E86 401	LINEAR EXPANSION VALVE			1		LEV			
19	G	R01 H09 202	GAS PIPE TEMPERATURE THERMISTOR		1	1		TH23			
20	G	R01 J25 480	HEAT EXCHANGER		1						
	G	R01 H99 480	HEAT EXCHANGER			1					
②1	G	T7W E01 072	DRAIN HOSE COVER		1	1					

FAN AND HEATER PARTS PCFY-P125VGM-E

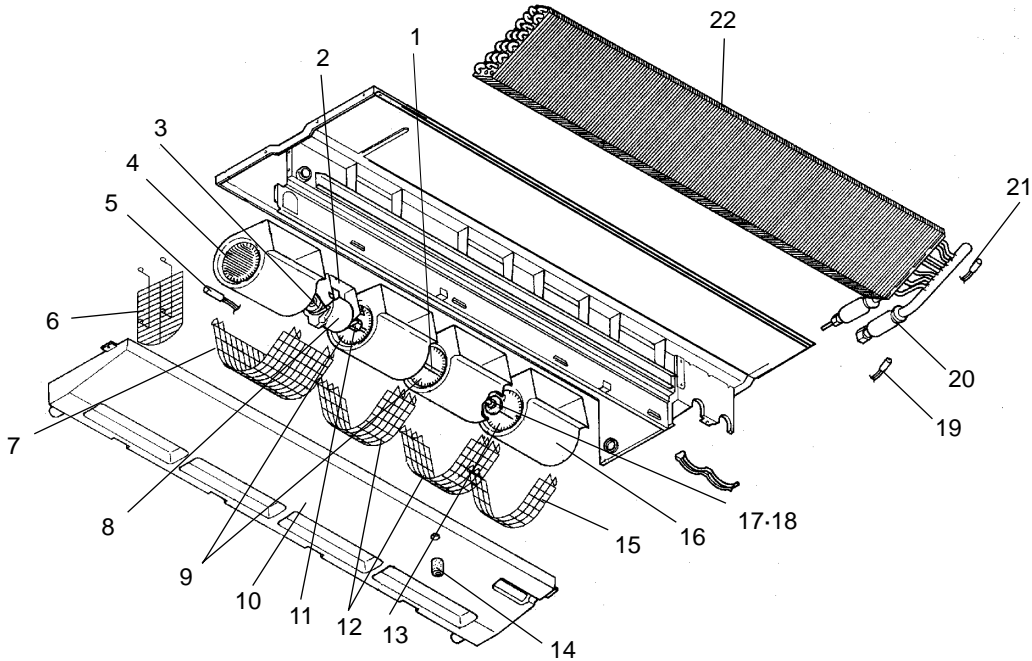

Part number that is circled is not shown in the figure.

No.	RoHS	Parts No.	Parts Name	Specifications	Q'ty/set PCFY- P125VGM-E	Remarks (Drawing No.)	Wiring Diagram Symbol	Recom- mended Q'ty	Price	
									Unit	Amount
1	G	R01 30J 100	SHAFT		1					
2	G	R01 33J 130	MOTOR LEG		1					
3	G	R01 45E 126	PIECE (MOTOR)		1	2pcs/set				
4	G	R01 E18 114	SIROCCO FAN		1					
5	G	R01 H08 202	ROOM TEMPERATURE THERMISTOR		1		TH21			
6	G	T7W 36J 675	FAN GUARD		1					
7	G	T7W 33J 675	FAN GUARD		1					
8	G	R01 20J 220	FAN MOTOR	D10B4P150MS	1		MF			
9	G	R01 E19 114	SIROCCO FAN		2					
10	G	R01 E29 529	DRAIN PAN ASSY		1					
11	G	R01 800 116	FAN JOINT		1					
12	G	T7W 34J 675	FAN GUARD		2					
13	G	R01 E20 114	SIROCCO FAN		1					
14	G	R01 18J 524	DRAIN PLUG		1					
15	G	T7W 35J 675	FAN GUARD		1					
16	G	R01 19J 110	CASING		4					
17	G	R01 E02 103	SLEEVE BEARING		1					
18	G	R01 36J 145	BEARING SUPPORT		1					
19	G	R01 H10 202	LIQUID PIPE TEMPERATURE THERMISTOR		1		TH22			
20	G	R01 E86 401	LINEAR EXPANSION VALVE		1		LEV			
21	G	R01 H09 202	GAS PIPE TEMPERATURE THERMISTOR		1		TH23			
22	G	R01 J00 480	HEAT EXCHANGER		1					
23	G	T7W E01 072	DRAIN HOSE COVER		1					

11**OPTIONAL PARTS****11-1. DRAIN-UP MACHINE**

Part No.	PAC-SE84DMA-E	PAC-SE85DMA-E	PAC-SE86DMA-E
Applied Service Ref.	PCFY-P40VGM-E	PCFY-P63VGM-E	PCFY-P100VGM-E PCFY-P125VGM-E

11-2. HIGH EFFICIENCY FILTER

Part No.	PAC-SE80KF-E	PAC-SE81KF-E	PAC-SE82KF-E
Applied Service Ref.	PCFY-P40VGM-E	PCFY-P63VGM-E PCFY-P100VGM-E	PCFY-P125VGM-E

CITY MULTI



HEAD OFFICE : TOKYO BLDG., 2-7-3, MARUNOUCHI, CHIYODA-KU, TOKYO100-8310, JAPAN